

Grizzly *Industrial, Inc.*®

MODEL G0641 DOUBLE MITER SAW OWNER'S MANUAL

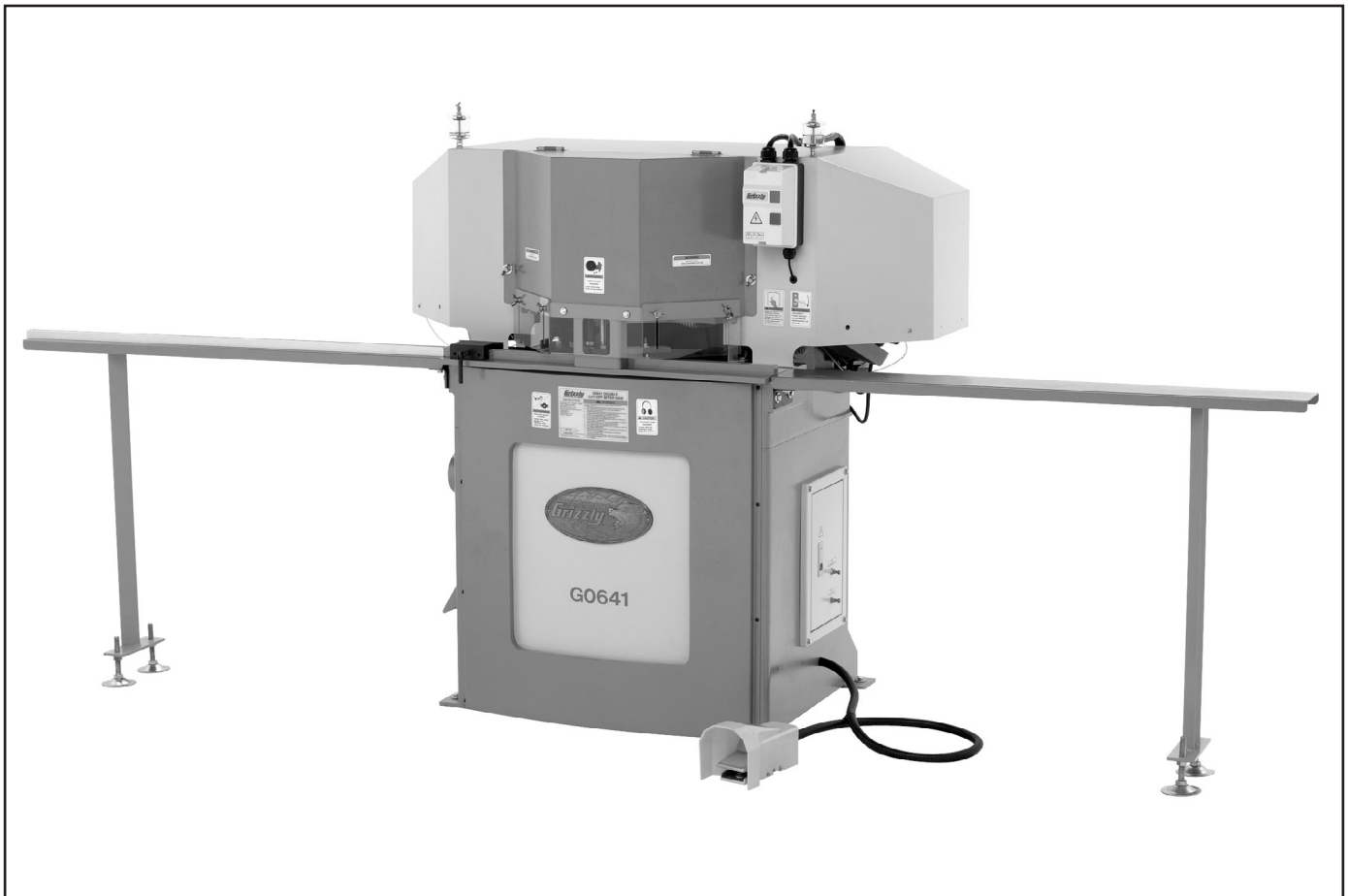

COPYRIGHT © JANUARY, 2008 BY GRIZZLY INDUSTRIAL, INC.
**WARNING: NO PORTION OF THIS MANUAL MAY BE REPRODUCED IN ANY SHAPE
OR FORM WITHOUT THE WRITTEN APPROVAL OF GRIZZLY INDUSTRIAL, INC.**
#TS9874 PRINTED IN TAIWAN



WARNING!

This manual provides critical safety instructions on the proper setup, operation, maintenance and service of this machine/equipment.

Failure to read, understand and follow the instructions given in this manual may result in serious personal injury, including amputation, electrocution or death.

The owner of this machine/equipment is solely responsible for its safe use. This responsibility includes but is not limited to proper installation in a safe environment, personnel training and usage authorization, proper inspection and maintenance, manual availability and comprehension, application of safety devices, blade/cutter integrity, and the usage of personal protective equipment.

The manufacturer will not be held liable for injury or property damage from negligence, improper training, machine modifications or misuse.



WARNING!

Some dust created by power sanding, sawing, grinding, drilling, and other construction activities contains chemicals known to the State of California to cause cancer, birth defects or other reproductive harm. Some examples of these chemicals are:

- **Lead from lead-based paints.**
- **Crystalline silica from bricks, cement and other masonry products.**
- **Arsenic and chromium from chemically-treated lumber.**

Your risk from these exposures varies, depending on how often you do this type of work. To reduce your exposure to these chemicals: Work in a well ventilated area, and work with approved safety equipment, such as those dust masks that are specially designed to filter out microscopic particles.

Table of Contents

INTRODUCTION.....	2	SECTION 5: ACCESSORIES.....	23
Foreword.....	2	SECTION 6: MAINTENANCE.....	26
Contact Info	2	Schedule.....	26
Machine Data Sheet.....	3	Cleaning.....	26
Identification.....	4	Lubrication	27
SECTION 1: SAFETY.....	5	V-Belt Maintenance	29
Safety Instructions for Machinery	5	SECTION 7: SERVICE	31
Safety Instructions for Double Miter Saws	7	Troubleshooting	31
SECTION 2: CIRCUIT REQUIREMENTS	8	Aligning Pivot Arm Assembly.....	34
220V Single-Phase	8	Pneumatic Limit Switch.....	35
SECTION 3: SETUP	9	Electrical Wiring Diagram	36
Setup Safety	9	Motor Wiring Diagram.....	37
Items Needed for Setup.....	9	Pneumatic System Diagram	38
Unpacking	9	SECTION 8: PARTS.....	39
Inventory	10	Cabinet.....	39
Clean Up.....	11	Drive System	41
Site Considerations.....	11	Pivot Linkage	43
Moving & Placing Machine	12	Extension Wings	44
Mounting to Shop Floor	13	Electrical & Lubrication Systems	45
Assembly	14	Pneumatic System.....	47
Air Supply	15	Label Placement	49
Dust Collection.....	16	WARRANTY AND RETURNS	53
Test Run	17		
SECTION 4: OPERATIONS	18		
Operation Safety	18		
Operational Overview	18		
Hold-downs	19		
Lowering Speeds	20		
Fence Stop	21		
Replacing Blades.....	22		

INTRODUCTION

Foreword

We are proud to offer the Model G0641 Double Miter Saw. This machine is part of a growing Grizzly family of fine woodworking machinery. When used according to the guidelines set forth in this manual, you can expect years of trouble-free, enjoyable operation and proof of Grizzly's commitment to customer satisfaction.

The specifications, drawings, and photographs illustrated in this manual represent the Model G0641 when the manual was prepared. However, owing to Grizzly's policy of continuous improvement, changes may be made at any time with no obligation on the part of Grizzly.

For your convenience, we always keep current Grizzly manuals available on our website at **www.grizzly.com**. Any updates to your machine will be reflected in these manuals as soon as they are complete. Visit our site often to check for the latest updates to this manual!

Contact Info

If you have any comments regarding this manual, please write to us at the address below:

Grizzly Industrial, Inc.
c/o Technical Documentation Manager
P.O. Box 2069
Bellingham, WA 98227-2069
Email: manuals@grizzly.com

We stand behind our machines. If you have any service questions or parts requests, please call or write us at the location listed below.

Grizzly Industrial, Inc.
1203 Lycoming Mall Circle
Muncy, PA 17756
Phone: (570) 546-9663
Fax: (800) 438-5901
E-Mail: techsupport@grizzly.com
Web Site: <http://www.grizzly.com>





MACHINE DATA SHEET

Customer Service #: (570) 546-9663 • To Order Call: (800) 523-4777 • Fax #: (800) 438-5901

MODEL G0641 DOUBLE MITER SAW

Product Dimensions:

Table Size	32 ⁵ / ₈ "W x 4"D
Overall Size (Machine Only)	57 ¹ / ₂ "W x 31 ⁵ / ₁₆ "D x 65"H
Overall Size (With Table).....	112 ¹ / ₂ "W x 28 ³ / ₈ "D x 57 ¹ / ₂ "H
Base Footprint.....	35 ³ / ₄ "W x 27 ³ / ₄ "D
Base Footprint (With Table).....	112 ¹ / ₂ "W x 28 ³ / ₈ "D
Table Height.....	33 ⁷ / ₈ "
In-Feed Extension Table Length.....	48"
Out-Feed Extension Table Length.....	48"
In-Feed and Out-Feed Extension Table Width	4 ¹ / ₂ "
Machine Weight	1012 lbs.

Shipping Dimensions:

Weight.....	1210 lbs.
Length/Width/Height.....	57"W x 31"D x 65"H

Motors:

Type	TEFC
Horsepower.....	2HP x 2
Phase/Voltage.....	Single Phase/220V
Cycle/RPM	60 Hz/1725 RPM
Amps	10A
Bearings	Shielded and Lubricated Ball Bearings

Electrical:

Switch Type	Magnetic with Thermal Overload Protection
Cord Length	98"
Cord Gauge	12 AWG
Minimum Circuit Size	30A

Main Specifications:

Cutting Angle	45°
Air Requirement	70 PSI
Saw Blade Size (Diameter x Width x Arbor x Teeth)	12" x 3MM x 1" x 120 (x2)
Max. Cut Width	2 ³ / ₄ "
Max. Cut Thickness	2 ³ / ₄ "
Max. Cut Length From Center	61"
Spindle Diameter	1"

Construction:

Base	Sheet Metal
Table	Sheet Metal
Motor Base.....	Pre-Formed Cast Iron
Spindle Bearings.....	Shielded and Lubricated Ball Bearings

Features:

- Creates two mitered workpieces in one cut for a perfect 90° joint.
- Foot pedal operated and pneumatically controlled.
- Included workpiece support stands with stop block system.
- Adjustable stroke speed for tear-out free cuts.
- Blade swing arm is micro-adjustable for perfect angles.



Identification

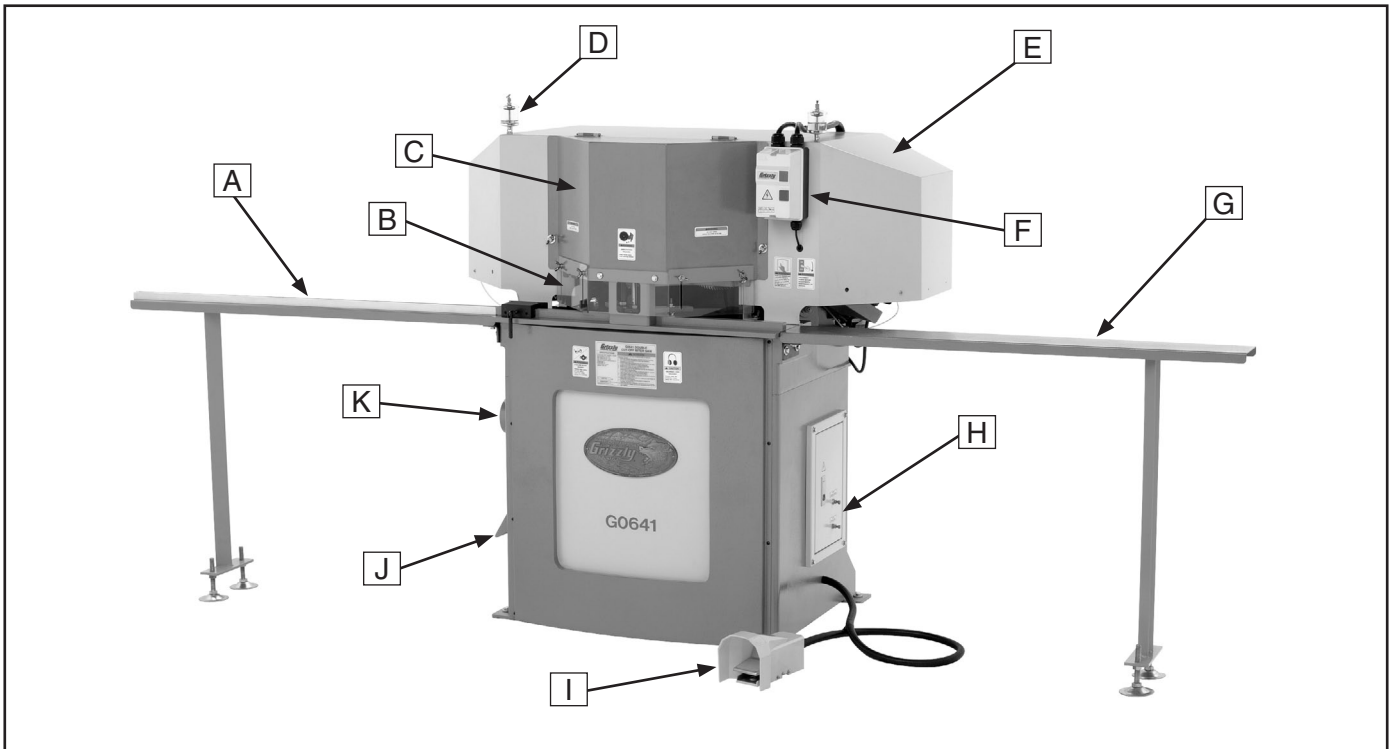

Figure 1. Model G0641 identification.

- | | |
|---------------------------------------|---|
| A. Left Extension Wing w/Scale | G. Right Extension Wing |
| B. Transparent Guard | H. Pneumatic Connections Access Door |
| C. Front Guard | I. Foot Pedal Actuator |
| D. Oil Reservoir | J. Waste Chute |
| E. Safety Hood | K. Dust Port 4" |
| F. ON/OFF Magnetic Switch | |



SECTION 1: SAFETY

WARNING

For Your Own Safety, Read Instruction Manual Before Operating this Machine

The purpose of safety symbols is to attract your attention to possible hazardous conditions. This manual uses a series of symbols and signal words intended to convey the level of importance of the safety messages. The progression of symbols is described below. Remember that safety messages by themselves do not eliminate danger and are not a substitute for proper accident prevention measures.



Indicates an imminently hazardous situation which, if not avoided, **WILL** result in death or serious injury.



Indicates a potentially hazardous situation which, if not avoided, **COULD** result in death or serious injury.



Indicates a potentially hazardous situation which, if not avoided, **MAY** result in minor or moderate injury. It may also be used to alert against unsafe practices.

NOTICE

This symbol is used to alert the user to useful information about proper operation of the machine.

WARNING

Safety Instructions for Machinery

- 1. READ THE ENTIRE MANUAL BEFORE STARTING MACHINERY.** Machinery presents serious injury hazards to untrained users.
- 2. ALWAYS USE ANSI APPROVED SAFETY GLASSES WHEN OPERATING MACHINERY.** Everyday eyeglasses only have impact resistant lenses—they are NOT safety glasses.
- 3. ALWAYS WEAR A NIOSH APPROVED RESPIRATOR WHEN OPERATING MACHINERY THAT PRODUCES DUST.** Most types of dust (wood, metal, etc.) can cause severe respiratory illnesses.
- 4. ALWAYS USE HEARING PROTECTION WHEN OPERATING MACHINERY.** Machinery noise can cause permanent hearing loss.
- 5. WEAR PROPER APPAREL. DO NOT** wear loose clothing, gloves, neckties, rings, or jewelry that can catch in moving parts. Wear protective hair covering to contain long hair and wear non-slip footwear.
- 6. NEVER OPERATE MACHINERY WHEN TIRED OR UNDER THE INFLUENCE OF DRUGS OR ALCOHOL.** Be mentally alert at all times when running machinery.



WARNING

Safety Instructions for Machinery

7. **ONLY ALLOW TRAINED AND PROPERLY SUPERVISED PERSONNEL TO OPERATE MACHINERY.** Make sure operation instructions are safe and clearly understood.
8. **KEEP CHILDREN AND VISITORS AWAY.** Keep all children and visitors a safe distance from the work area.
9. **MAKE WORKSHOP CHILDPROOF.** Use padlocks, master switches, and remove start switch keys.
10. **NEVER LEAVE WHEN MACHINE IS RUNNING.** Turn power **OFF** and allow all moving parts to come to a complete stop before leaving machine unattended.
11. **DO NOT USE IN DANGEROUS ENVIRONMENTS.** DO NOT use machinery in damp, wet locations, or where any flammable or noxious fumes may exist.
12. **KEEP WORK AREA CLEAN AND WELL LIGHTED.** Clutter and dark shadows may cause accidents.
13. **USE A GROUNDED EXTENSION CORD RATED FOR THE MACHINE AMPERAGE.** Grounded cords minimize shock hazards. Undersized cords create excessive heat. Always replace damaged extension cords.
14. **ALWAYS DISCONNECT FROM POWER SOURCE BEFORE SERVICING MACHINERY.** Make sure switch is in OFF position before reconnecting.
15. **MAINTAIN MACHINERY WITH CARE.** Keep blades sharp and clean for best and safest performance. Follow instructions for lubricating and changing accessories.
16. **MAKE SURE GUARDS ARE IN PLACE AND WORK CORRECTLY BEFORE USING MACHINERY.**
17. **REMOVE ADJUSTING KEYS AND WRENCHES.** Make a habit of checking for keys and adjusting wrenches before turning machinery **ON**.
18. **CHECK FOR DAMAGED PARTS BEFORE USING MACHINERY.** Check for binding or misaligned parts, broken parts, loose bolts, and any other conditions that may impair machine operation. Repair or replace damaged parts before operation.
19. **USE RECOMMENDED ACCESSORIES.** Refer to the instruction manual for recommended accessories. Improper accessories increase risk of injury.
20. **DO NOT FORCE MACHINERY.** Work at the speed for which the machine or accessory was designed.
21. **SECURE WORKPIECE.** Use clamps or a vise to hold the workpiece when practical. A secured workpiece protects your hands and frees both hands to operate the machine.
22. **DO NOT OVERREACH.** Maintain stability and balance at all times.
23. **MANY MACHINES CAN EJECT WORKPIECES TOWARD OPERATOR.** Know and avoid conditions that cause the workpiece to "kickback."
24. **ALWAYS LOCK MOBILE BASES (IF USED) BEFORE OPERATING MACHINERY.**
25. **CERTAIN DUST MAY BE HAZARDOUS** to the respiratory systems of people and animals, especially fine dust. Be aware of the type of dust you are exposed to and always wear a respirator designed to filter that type of dust.



WARNING

Safety Instructions for Double Miter Saws

- 1. SAFETY GUARDS.** The safety guards are designed to protect you from the spinning blades and flying debris during operation. Always keep the safety guards in their correct position when the machine is in operation.
- 2. KICKBACK.** Be familiar with kickback. Kickback happens when the workpiece is thrown towards the operator at a high rate of speed. *Until you have a clear understanding of kickback and how it occurs, DO NOT operate this saw!*
- 3. WORKPIECE CONTROL.** To avoid kickback, make sure the workpiece is stable on the table and is supported by the fence, extension wings, and pneumatic hold-downs. DO NOT perform any cutting operations free-hand.
- 4. REACHING NEAR SAFETY GUARDS.** The spinning saw blades can cause serious personal injury very quickly. Never reach near or under safety guards when the machine is connected to power. Disconnect the machine from power before placing your hands within 4" of the safety guards.
- 5. DAMAGED SAW BLADES.** Never use blades that have been dropped or otherwise damaged.
- 6. USE CORRECT AIR PRESSURE.** Exceeding the maximum 90 PSI air pressure rating of this machine may cause unpredictable operation, personal injury, or damage to the machine.
- 7. DISCONNECT AIR PRESSURE.** To avoid the risk of unintentional operation, disconnect air pressure when the machine is not in use. Always disconnect air pressure from the machine when performing maintenance, setup, or service.
- 8. BE AWARE OF AIR HOSE LOCATION.** Hoses can easily become a tripping hazard when laid across the floor in a disorganized manner.
- 9. STALLED BLADE.** Disconnect the saw from power before attempting to "free" a stalled saw blade or jammed workpiece.
- 10. WORKPIECE SUPPORT.** Provide adequate support for workpieces that extend beyond the extension wings.
- 11. STABLE POSITION.** Avoid operations and hand positions where a slip could cause your hand to move into the blade.
- 12. MACHINE CONDITION.** If any part of the machine is damaged or not working properly, STOP using the machine immediately. To avoid the risk of serious personal injury, make sure that proper repairs are completed before re-connecting the machine to power.
- 13. EXPERIENCING DIFFICULTIES.** If at any time you are experiencing difficulties performing the intended operation, stop using the machine! Contact our Service Department at (570) 546-9663.

WARNING

Like all machinery there is potential danger when operating this machine. Accidents are frequently caused by lack of familiarity or failure to pay attention. Use this machine with respect and caution to lessen the possibility of operator injury. If normal safety precautions are overlooked or ignored, serious personal injury may occur.



SECTION 2: CIRCUIT REQUIREMENTS

220V Single-Phase

!WARNING

Serious personal injury could occur if you connect the machine to power before completing the setup process. **DO NOT** connect the machine to the power until instructed later in this manual.



!WARNING

Electrocution or fire could result if machine is not grounded and installed in compliance with electrical codes. Compliance **MUST** be verified by a qualified electrician!

Full Load Amperage Draw

Total Motor Draw 20 Amps

Power Supply Circuit Requirements

You **MUST** connect your machine to a grounded circuit that is rated for the amperage given below. Never replace a circuit breaker on an existing circuit with one of higher amperage without consulting a qualified electrician to ensure compliance with wiring codes. **If you are unsure about the wiring codes in your area or you plan to connect your machine to a shared circuit, consult a qualified electrician.**

Minimum Circuit Size..... 30 Amps

Power Connection Device

The type of plug required to connect your machine to power depends on the type of service you currently have or plan to install. We recommend using the plug and receptacle shown in **Figure 2**.

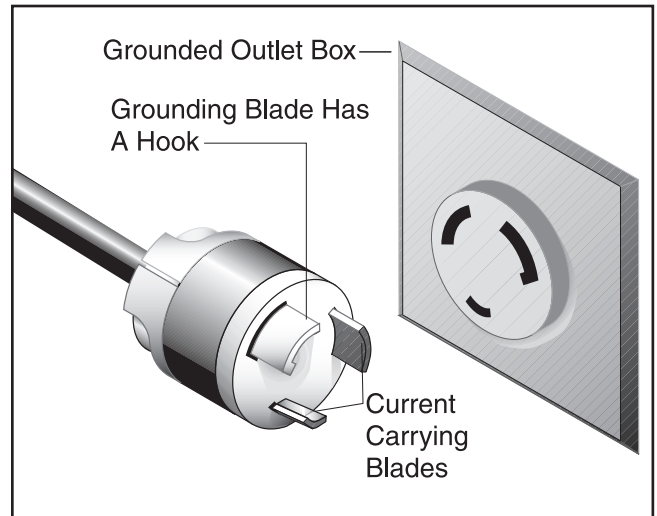

Figure 2. NEMA L6-30 plug and receptacle.

Extension Cords

Using extension cords may reduce the life of the motor. Instead, place the machine near a power source. If you must use an extension cord:

- Use at least a 12 gauge cord that does not exceed 50 feet in length.
- The extension cord must have a ground wire and plug pin.
- A qualified electrician **MUST** size cords over 50 feet long to prevent motor damage.



SECTION 3: SETUP

Setup Safety

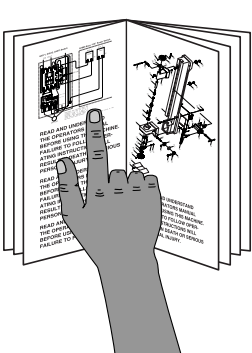

! WARNING
 This machine presents serious injury hazards to untrained users. Read through this entire manual to become familiar with the controls and operations before starting the machine!



! WARNING
 Wear safety glasses during the entire setup process!



! WARNING
 This machine and its components are very heavy. Get lifting help or use power lifting equipment such as a forklift to move heavy items.

Items Needed for Setup

The following items are needed to complete the setup process, but are not included with your machine:

Description	Qty
• Straightedge 4' (or longer)	1
• Precision Level	1
• Assistants	At Least 1
• Safety Glasses (for each person)	1
• Dust Collection System	1
• 4" Dust Hose (length as needed)	1
• 4" Hose Clamp	1
• Air Compressor	1
• Air Hose (length as needed)	1
• Forklift (rated for 1500 lbs.)	1

Unpacking

Your machine was carefully packaged for safe transportation. Remove the packaging materials from around your machine and inspect it. If you discover the machine is damaged, *please immediately call Customer Service at (570) 546-9663 for advice.*

Save the containers and all packing materials for possible inspection by the carrier or its agent. *Otherwise, filing a freight claim can be difficult.*

When you are completely satisfied with the condition of your shipment, inventory the contents.



Inventory

The following is a description of the main components shipped with your machine. Lay the components out to inventory them.

Note: *If you can't find an item on this list, check the mounting location on the machine or examine the packaging materials carefully. Occasionally we pre-install certain components for shipping purposes.*

Inventory: (Figures 3)	Qty
A. Double Miter Saw (not shown).....	1
B. Left Extension Wing w/Scale.....	1
C. Right Extension Wing.....	1
D. Support Legs w/Adjustable Floor Mounts ..	2
E. Hex Wrench Set 1.5–10mm.....	1
F. Combo Wrenches:	
—11/13mm.....	1
—12/14mm.....	1
—17/19mm.....	1
—22/24mm.....	1
—23/26mm.....	1
G. Hardware Bag (not shown):	
—Special Hex Bolts 5/8-11 x 2 ³ / ₈ "	
(lifting).....	4
—Hex Nuts 5/8"-11 (lifting).....	4
—Hex Bolts M8-1.25 x 25 (ext. wings)	8
—Flat Washers 8mm (ext. wings).....	8

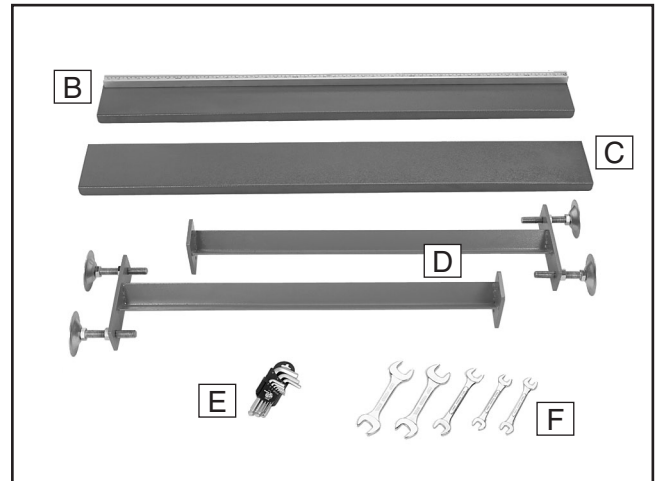

Figure 3. Extension wings and tools.

If any nonproprietary parts are missing (e.g. a nut or a washer), we will gladly replace them; or for the sake of expediency, replacements can be obtained at your local hardware store.

⚠ WARNING

SUFFOCATION HAZARD!

Immediately discard all plastic bags and packing materials to eliminate choking/suffocation hazards for children and animals.



Clean Up

The unpainted surfaces are coated with a waxy oil to prevent corrosion during shipment. Remove this protective coating with a solvent cleaner or citrus-based degreaser such as Grizzly's G7895 Citrus Degreaser. To clean thoroughly, some parts must be removed. **For optimum performance from your machine, clean all moving parts or sliding contact surfaces.** Avoid chlorine-based solvents, such as acetone or brake parts cleaner that may damage painted surfaces. Always follow the manufacturer's instructions when using any type of cleaning product.

	<p>! WARNING Gasoline and petroleum products have low flash points and can explode or cause fire if used to clean machinery. DO NOT use these products to clean the machinery.</p>
--	--

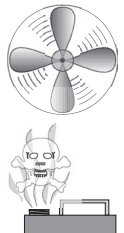
	<p>! CAUTION Many cleaning solvents are toxic if inhaled. Minimize your risk by only using these products in a well ventilated area.</p>
---	---

G7895—Grizzly Citrus Degreaser

This natural, citrus-based degreaser is a great solution for removing export grease, and it's much safer to work around than nasty solvents.

<p>Call 1-800-523-4777 To Order</p>	
--	---

Figure 4. Grizzly citrus degreaser.

Site Considerations

Floor Load

Refer to the **Machine Data Sheet** on **Page 3** for the weight and footprint specifications of your machine. Some floors may require additional reinforcement to support both the machine and operator.

Placement Location

Consider existing and anticipated needs, size of material to be processed through each machine, and space for auxiliary stands, work tables or other machinery when establishing a location for your new machine. See **Figure 5** for the minimum working clearances.

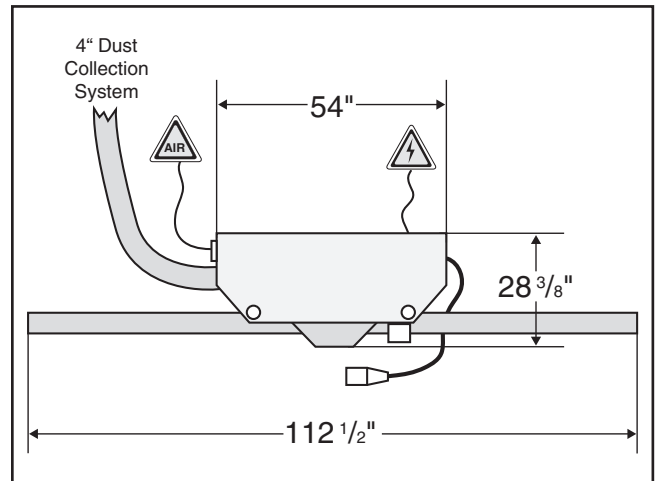
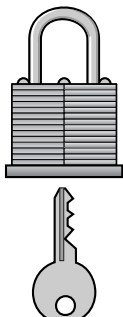
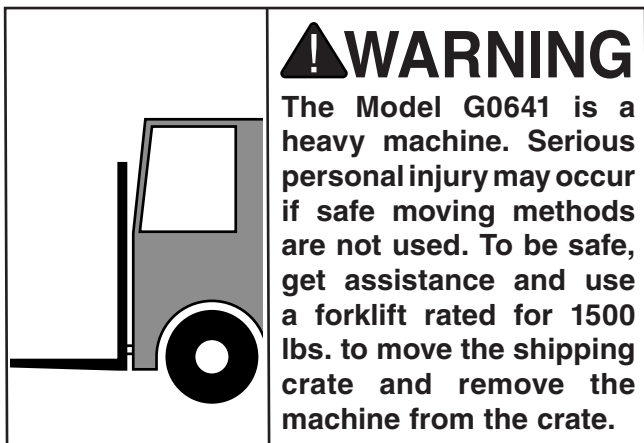

Figure 5. Minimum working clearances.

	<p>! CAUTION Children and visitors may be seriously injured if unsupervised around this machine. Lock entrances to the shop or disable start switch or power connection to prevent unsupervised use.</p>
--	---



Moving & Placing Machine



Lifting hex bolts are included with your saw so that you can raise the machine from the shipping pallet far enough to insert forklift forks for moving.

To move the machine:

1. Remove the top wooden crate from the machine and shipping pallet.
2. Remove the four lag bolts and washers securing the machine to the pallet.



3. Use a 24mm wrench to thread the four special 5/8-11 x 2³/₈" hex bolts into the machine mounting flanges (see **Figure 6**).

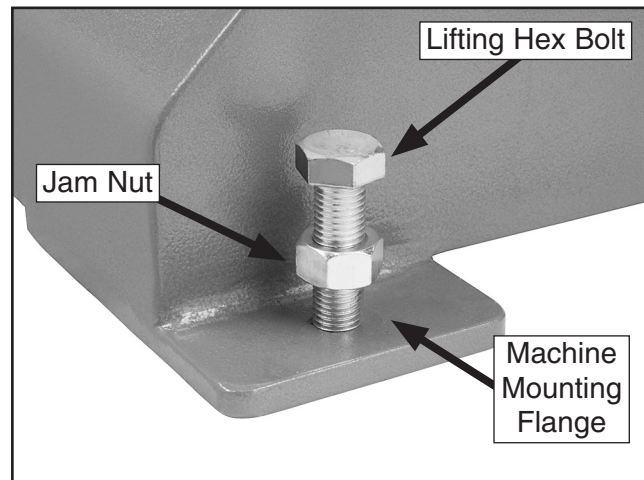

Figure 6. Lifting hex bolts and jam nuts.

4. Evenly tighten the four lifting hex bolts to raise the machine up from the pallet far enough to insert forklift forks under the machine, then tighten the jam nuts down to the mounting flange to lock the lifting bolts in place.
5. Spread the forklift forks as far as possible and insert them under the machine.
6. With assistance to steady the load, slowly lift the machine from the pallet and move it to your prepared location.

Note: Place a precision level on the table and shim under the machine as necessary to make it level. Take care to shim any gaps between the mounting flanges and the floor before tightening the lag bolts to prevent the cast iron cabinet from warping or cracking.



Mounting to Shop Floor

Although not required, we recommend that you mount your new machine to the floor. Because this is an optional step and floor materials may vary, floor mounting hardware is not included. Generally, you can either bolt your machine to the floor or mount it on machine mounts. Both options are described below. Whichever option you choose, it is necessary to level your machine with a precision level.

Bolting to Concrete Floors

Anchor studs and lag shield anchors with lag bolts (Figure 7) are two popular methods for anchoring an object to a concrete floor. We suggest you research the many options and methods for mounting your machine and choose the best that fits your specific application.

NOTICE

Anchor studs are stronger and more permanent alternatives to lag anchors and bolts; however, they will stick out of the floor, which may cause a tripping hazard if you decide to move your machine.

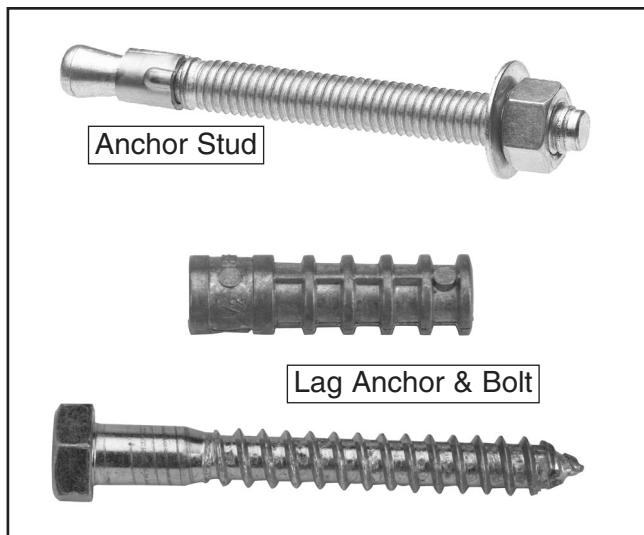

Figure 7. Typical fasteners for mounting to concrete floors.

Using Machine Mounts

Using machine mounts, shown in Figure 8, gives the advantage of fast leveling and vibration reduction. The large size of the foot pads distributes the weight of the machine to reduce strain on the floor.



Figure 8. Machine mount example.

NOTICE

We strongly recommend securing your machine to the floor if it is hardwired to the power source. Consult with your electrician to ensure compliance with local codes.



Assembly

Once you have secured the machine in its prepared location, install the extension wings.

To assemble the double miter saw:

1. Turn the extension wings upside down on a protected surface (see **Figure 9**).

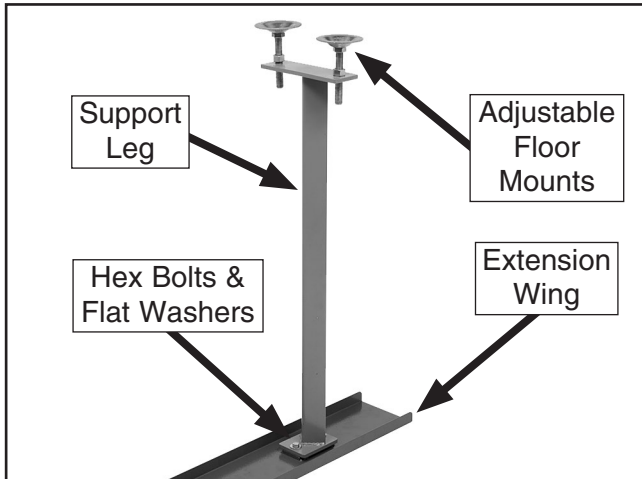

Figure 9. Extension wing with support leg installed.

2. Use a 13mm wrench to secure the support legs to the extension wings with the M8-1.25 x 20 hex bolts and flat washers, as shown in **Figure 9**.

3. Turn the support leg and extension wing assemblies right side up and mount them to the flanges on both sides of the saw table (see **Figure 10**) with the M8-1.25 x 20 hex bolts and flat washers.

Note: *The extension wing with the scale is mounted on the left side of the machine.*



Figure 10. Extension wing mounted onto the saw table.

4. Lay a long straightedge across the extension wings and the saw table.
5. Adjust the supporting leg floor mounts so that the extension wings are level with the table, then tighten the jam nuts on the floor mounts to secure the settings.



Air Supply

Required Air PSI.....	70 PSI
Air Consumption.....	4 CFM
Maximum Air PSI.....	90 PSI

To connect the saw to compressed air:

1. Connect a source of compressed air to the air regulator-lubricator inlet valve on the back (see **Figure 11**).

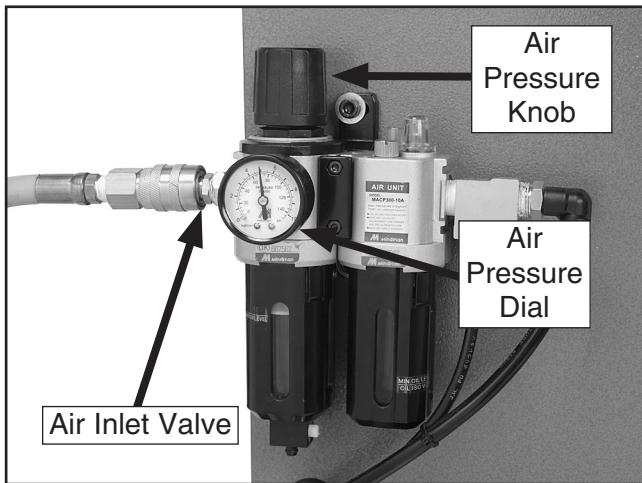

Figure 11. Air regulator-lubricator.

2. Lift up on the air pressure knob (see **Figure 11**), and turn it to adjust the air pressure dial to 70 PSI, then push the knob down to lock the setting.
3. Open the pneumatic access door on the right side of the machine and set the air pressure knob in a similar manner so that the air pressure dial reads 70 PSI (see **Figure 12**).

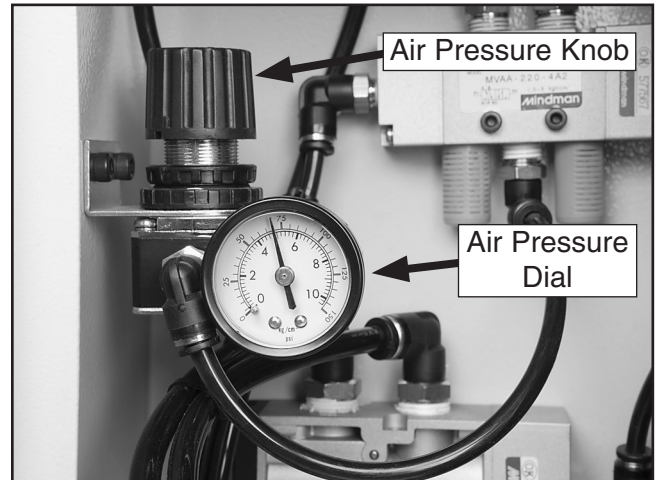

Figure 12. Internal air regulator.

NOTICE

Exceeding 90 PSI may result in unpredictable operation of the saw and damage to the pneumatic system.



Dust Collection

⚠ CAUTION

DO NOT operate the Model G0641 without an adequate dust collection system. This saw creates substantial amounts of wood dust while operating. Failure to use a dust collection system can result in short and long-term respiratory illness.

Recommended CFM at Dust Port: 400 CFM

Do not confuse this CFM recommendation with the rating of the dust collector. To determine the CFM at the dust port, you must consider these variables: (1) CFM rating of the dust collector, (2) hose type and length between the dust collector and the machine, (3) number of branches or wyes, and (4) amount of other open lines throughout the system. Explaining how to calculate these variables is beyond the scope of this manual. Consult an expert or purchase a good dust collection "how-to" book.

To connect a dust collection hose:

1. Fit a 4" dust hose over the dust port, as shown in **Figure 13**, and secure it in place with a hose clamp.
2. Tug the hose to make sure it does not come off.

Note: *A tight fit is necessary for proper performance.*



Figure 13. Dust hose attached to dust port.



Test Run

Once the assembly is complete, test run your machine to make sure it runs properly. The test run consists of verifying the following: 1) The saw motors power up and run correctly, and 2) the front guard safety feature works correctly.

If, during the test run, you cannot easily locate the source of an unusual noise, vibration, or action, stop using the machine immediately, then review the **Troubleshooting** on **Page 31**.

If you still cannot remedy a problem, contact our Tech Support at (570) 546-9663 for assistance.

To test run the machine:

1. Make sure you have read and understand the safety instructions at the beginning of the manual and that the machine is setup properly.
2. Check for proper lubrication (refer to **Lubrication** on **Page 27**).
3. Make sure the saw blades are firmly secured by the arbor bolts and flanges (refer to **Replacing Blades** on **Page 22** for detailed instructions).
4. Make sure all tools and objects used during set up are cleared away from the machine.
5. Connect the machine to the power and air, correctly adjust the air pressure on both regulators, then turn the machine **ON**.
6. Listen to and watch for abnormal noises or actions. The machine should run smoothly with little or no vibration or rubbing noises.
 - Strange or unusual noises should be investigated and corrected before operating the machine further. Always disconnect the machine from power when investigating or correcting potential problems.
7. Turn the power **OFF**.

8. Press the foot pedal actuator—the hold-downs and blades should lower. Lift your foot from the pedal—the blades and hold-down should raise.
9. Remove the two thumb screws securing the front guard (see **Figure 14**) and swing the guard up, as shown in **Figure 15**.

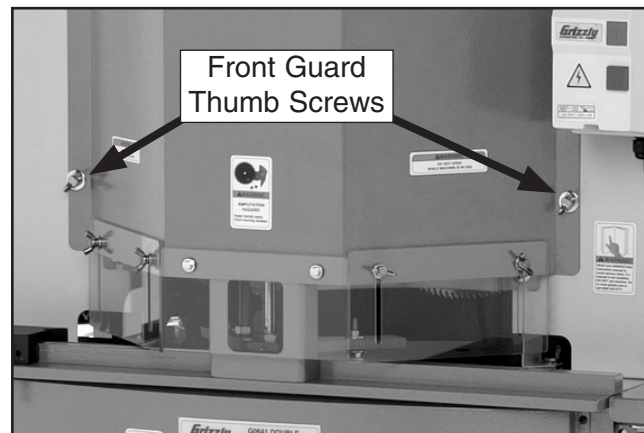

Figure 14. Front guard thumb screws.



Figure 15. Front guard in the upper position.

10. Standing away from the front of the saw, turn the machine **ON**.
 - If the machine **DOES NOT** start, the front guard safety feature is working correctly. Lower the front guard and secure it with the two thumb screws before proceeding.
 - If the machine **DOES** start (with the front guard raised up), immediately disconnect power to the machine. The front guard safety switch (**Figure 15**) is not working correctly. This safety feature must work properly before proceeding with the rest of the test run. Call Tech Support for help.



SECTION 4: OPERATIONS

Operation Safety

!WARNING

Damage to your eyes, lungs, and ears could result from using this machine without proper protective gear. Always wear safety glasses, a respirator, and hearing protection when operating this machine.

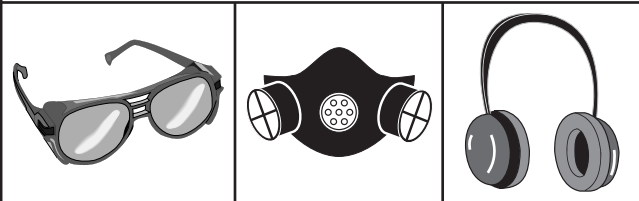

!WARNING

Loose hair and clothing could get caught in machinery and cause serious personal injury. Keep loose clothing and long hair away from moving machinery.

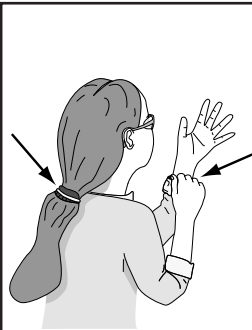

NOTICE

If you have never used this type of machine or equipment before, WE STRONGLY RECOMMEND that you read books, trade magazines, or get formal training before beginning any projects. Regardless of the content in this section, Grizzly Industrial will not be held liable for accidents caused by lack of training.

Operational Overview

The Model G0641 was designed to make two precise and matching 45° cuts in a high-production shop. This is accomplished by using two opposing 12" saw blades and motors, with the blades rotating down through the workpiece in guillotine-type movement.

The stock is positioned on the table up against the fence and the adjustable stop. When the foot pedal actuator is pressed, the pneumatic hold-downs lower to hold the workpiece and the blades swing down in a controlled manner to make the cuts.

The resulting workpiece will have opposing 45° cuts on the ends, and the triangular waste piece exits the machine down through the waste chute.

The vertical movement of the clamping hold-downs and saw blades is pneumatically controlled and the rate can be independently adjusted.

To make a cut:

1. Position the hold-downs to firmly hold the workpiece against the fence (**Page 19**).
2. Adjust the lowering rates for the hold-downs and saw blades (**Page 20**).
3. Set the fence stop at the correct distance for your operation (**Page 21**).
4. Turn the saw **ON**, then press the foot pedal actuator to make the cut.



Hold-downs

The purpose of the pneumatic hold-downs is to secure the stock in the desired position up against the fence and to prevent the workpiece from being drawn into the center of the saw by the rotational force of the blades.

CAUTION

The pneumatic hold-downs must be correctly adjusted to firmly hold the workpiece against the fence before the cutting operation begins. If the workpiece is drawn into the saw by the rotation force of the blades, personal injury or damage to the machine may occur.

To correctly adjust the hold-downs:

1. DISCONNECT SAW FROM POWER!
2. DISCONNECT SAW FROM AIR SUPPLY!
3. Remove the two thumb screws from the front guard and raise it to the upper position.

NOTICE

When the front guard is in the upper position, the machine cannot be turned **ON**. When the front guard is secured in the down position, the safety switch is activated and power can flow to the motor.

4. Position your workpiece under the hold-downs, then lower the hold-downs by hand until they touch the workpiece (see **Figure 16**).

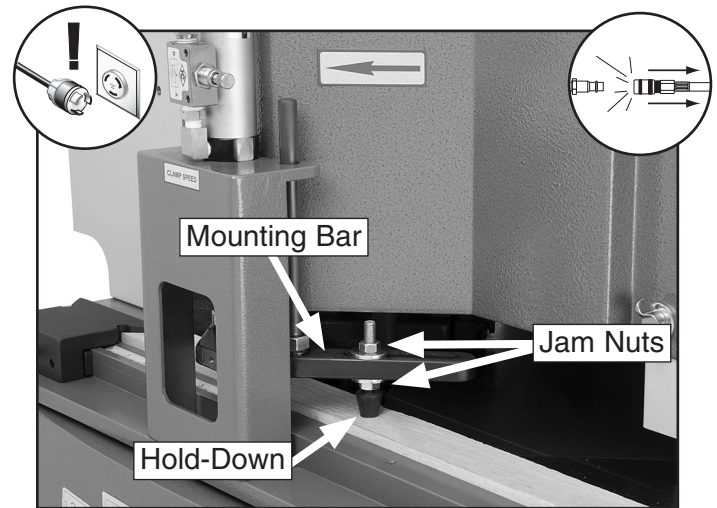

Figure 16. Workpiece hold-down.

5. Use a 13mm wrench to loosen the upper and lower hold-down jam nuts.
6. Position the hold-downs horizontally along the mounting bars over the flattest part of the workpiece so that they grip and secure the workpiece against the fence.
7. Re-tighten the jam nuts to keep the hold-downs in place.
8. Lower the front guard and secure it in place with the thumb screws.
9. Adjust the side transparent guards just slightly above the workpiece for maximum protection.
10. Re-connect the machine to the air supply, then press the foot pedal actuator to test the positioning of the hold-downs. Repeat the steps above if necessary.



Lowering Speeds

The lowering speeds of the hold-downs and blades are independently adjustable. The goal is to synchronize these rates so that the hold-downs grip the workpiece before the blades begin the cut. After the cut is complete and the blades are fully raised, the hold-downs will raise and release the workpiece.

When making adjustments, first adjust the lowering speed of the blades, then adjust the lowering speed of the hold-downs.

To adjust the lowering and raising rate of the saw blades:

1. DISCONNECT SAW FROM POWER!

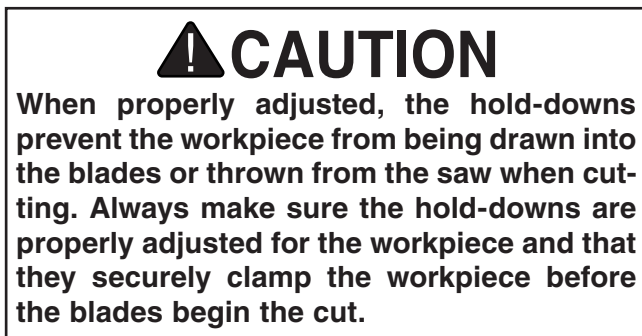

2. Loosen the jam nuts on the blade lowering and raising speed knobs (see **Figure 17**).

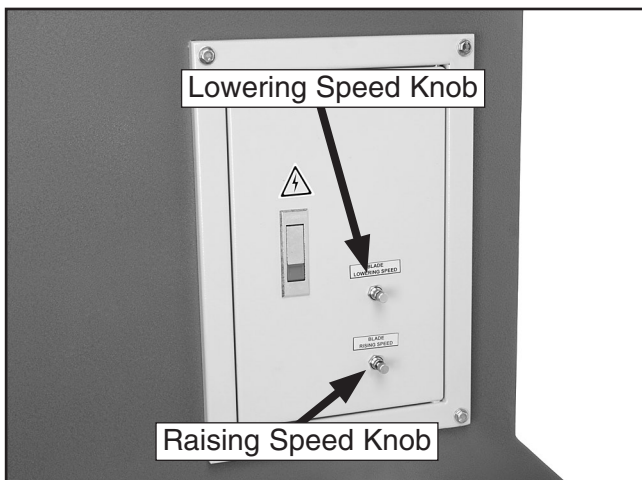

Figure 17. Saw blade lowering and raising speed controls (on right side of machine).

3. Secure a scrap piece of the same material you will use for the production run under the hold-downs, then lower and secure the front guard.
 4. Connect the saw to power, turn the motor on, and use the foot pedal actuator to make test cuts.
 5. Adjust the lowering and raising speeds of the blades to produce cuts that are without tear out (too fast) and without burning (too slow).
- Note:** Turning the speed knob in (clockwise) decreases the speed, and turning out (counterclockwise) increases it.
6. Continue to make adjustments and test cuts until you are satisfied with the lowering and raising speeds of the blade, then re-tighten the jam nut to secure the setting.

To adjust the lowering rate of the hold-downs:

1. DISCONNECT SAW FROM POWER!
2. Remove the two thumb screws from the front guard and raise it to the upper position.



3. Loosen the jam nut on the hold-down (clamp) lowering speed knob, then turn the knob to adjust the speed (see **Figure 18**).

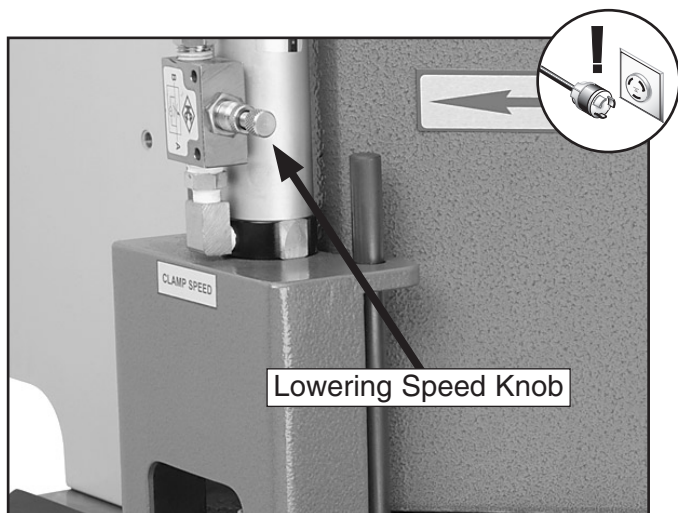

Figure 18. Hold-down lowering speed control.

4. Remove any material from the table, keep your hands clear of the cutting area, then press the foot pedal actuator to test the lowering speeds of the hold-downs and blades.

Note: *The goal is to make the hold-downs clamp the workpiece BEFORE the saw blades begin the cut.*

5. When you are satisfied with the adjustment, re-tighten the jam nut, then lower and secure the front guard.

Fence Stop

Use the fence stop for repetitive cuts of the same dimensions. Loosen the lock lever, slide the stop along the fence rail to the correct setting, then re-tighten the lever (see **Figure 19**).

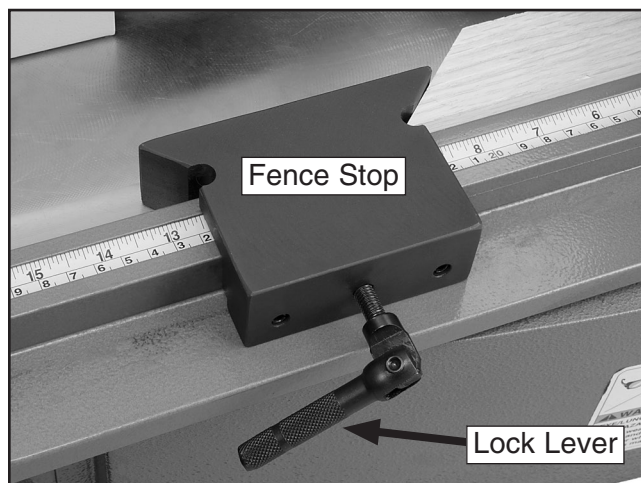

Figure 19. Fence stop.

⚠️ WARNING

The saw blades can remove fingers and hands very quickly. Always keep your hands at least 4" away from the front guard when the saw blades are spinning. If necessary, use push sticks and other safety devices to handle the workpiece.



Replacing Blades

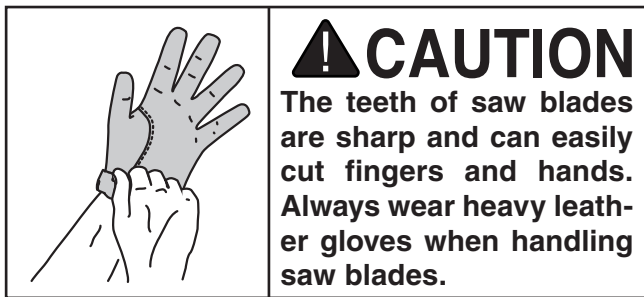

The Model G0641 comes with two high-quality 12", 120-tooth blades. For best cutting results, select replacement blades that are designed for miter cuts and are of high quality.

To replace the saw blades:

1. DISCONNECT SAW FROM POWER!
2. Raise the front guard up, and remove the inner blade guard to access the blade arm assemblies and motors (see **Figure 20**).

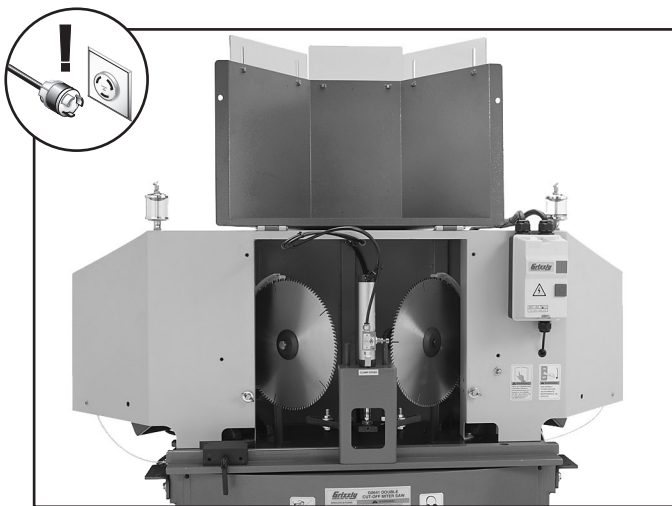

Figure 20. Guards removed to access blade arm assemblies and motors.

3. Use a 14mm wrench on the inner arbor nut (see **Figure 35**) and a 19mm wrench on the arbor bolt to remove the arbor bolt, arbor flange, and saw blade.

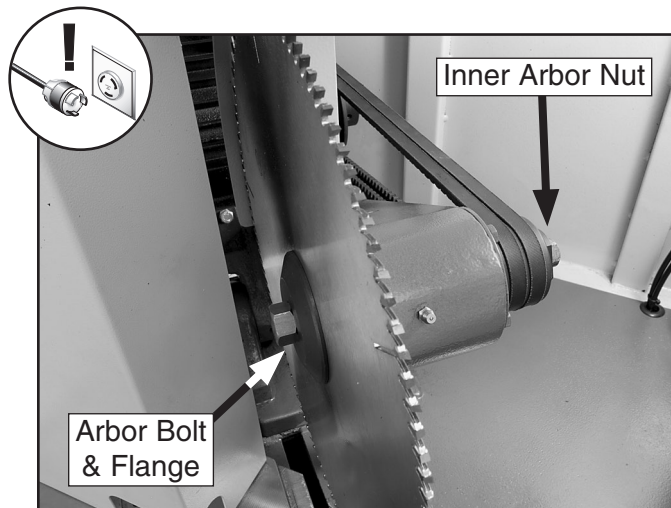

Figure 21. Blade arbor bolt, flange, and nut (left side shown).

Note: The left saw blade has a left-hand arbor bolt—to remove it, turn it clockwise. The right saw blade has a normally threaded arbor bolt and is removed by turning it counterclockwise.

4. Install the new blade on the arbor so that the teeth are pointing forward.
 5. Secure the blade with the arbor flange and bolt.
- Note:** The arbor flange **MUST** be installed to ensure the blade is safely secured.
6. Reinstall the inner blade guard and secure the front guard in the lower position.



SECTION 5: ACCESSORIES

G8982—Shop Fox Roller Table

Use this versatile roller table wherever you need extra workpiece support. Features all steel welded construction and measures 19" x 65" long. Comes with 9 ball bearing rollers and has four independently adjustable legs for any leveling requirement. Adjustable in height from 26³/₈" to 44¹/₈".



Figure 22. G8982 Shop Fox roller table.

G1955—OxiSolv® Blade & Bit Cleaner

Used to clean the gummy pitch and residue from saw blades and router bits, this high quality cleaner will make blades and bits last longer while improving cutting action.



Figure 23. G1955 OxiSolv® spray.

Call 1-800-523-4777 To Order

Forest ChopMaster

H4751—12", 80 TPI, 1" Arbor

This top quality miter saw produces perfectly cut miter joints. Made with double hard C4 submicron carbide for up to 300% longer life. A heavier than normal steel plate and a negative face hook maintain maximum stability for the best cut. Each blade is hand straightened to a runout of 0.001/0.002" for maximum cut quality. The tooth style (4 points and a flat) maximizes steady, clean cuts with no bottom splintering. You will be amazed by the extra-smooth, tight cuts you will get with this blade.

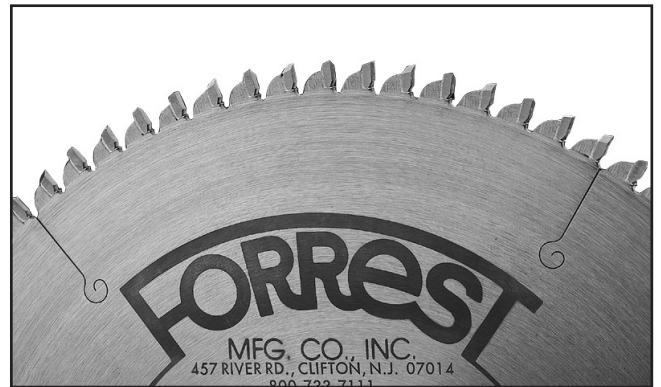

Figure 24. H4751 12" miter saw blade.

H4978—Deluxe Earmuffs - 27dB

H4979—Twin Cup Hearing Protector - 29dB

H4977—Work-Tunes Radio Earmuffs - 25dB

Protect yourself comfortably with a pair of cushioned earmuffs. Especially important if you or employees operate for hours at a time.



Figure 25. Our most popular earmuffs.



Oldham® Pro Series Precision Cut-Off Blades
H9364—12", 60 TPI, 1" Arbor
H9367—12", 80 TPI, 1" Arbor

Special recipe tungsten micrograin carbide provides excellent impact resistance while allowing keen, extremely sharp cutting edges.



Figure 26. Oldham® Pro Series Blade.

- G5562—SLIPIT® 1 Qt. Gel
- G5563—SLIPIT® 12 oz Spray
- G2871—Boeshield® T-9 12 oz Spray
- G2870—Boeshield® T-9 4 oz Spray
- H3788—G96® Gun Treatment 12 oz Spray
- H3789—G96® Gun Treatment 4.5 oz Spray



Figure 27. Recommended products for protecting unpainted cast iron/steel part on machinery.

Call 1-800-523-4777 To Order

- T20501—Face Shield, 4" Crown, Clear
- T20502—Face Shield, 7" Crown, Clear
- T20448—Economy Clear Safety Glasses
- T20452—"Kirova" Anti-Reflective Glasses
- T20456—"Dakura" Clear Safety Glasses
- H0736—Shop Fox® Safety Glasses

These glasses meet ANSI Z87.1-2003 specifications. Buy extras for visitors or employees. You can't be too careful with shop safety!

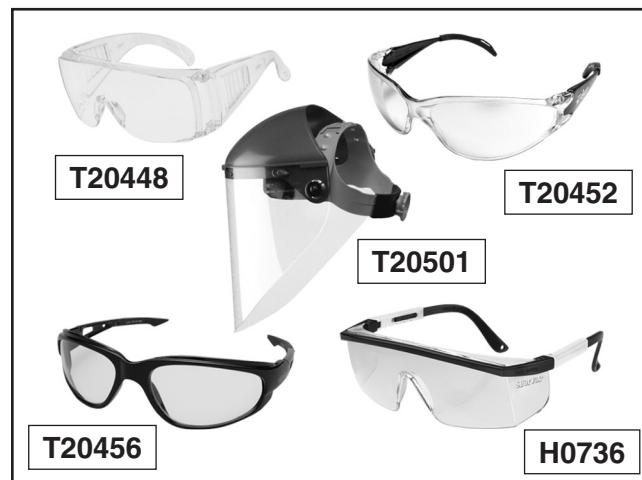

Figure 28. Our most popular eye protection.

Campbell Hausfeld™ Air Compressor & Tool Oil

- G2820—8 oz.
- G2821—1 pint

These Campbell Hausfeld™ lubricants offer outstanding heat displacement and friction reduction without eating away at O-rings and other rubber components.



Figure 29. Campbell Hausfeld™ Air Compressor & Tool Oil



Shop Fox 90° Corner Clamps
H5575—2¼" Clamping Capacity
H5576—4¼" Clamping Capacity

Cast iron 90° corner clamps hold mitered cuts securely for gluing and fastening.

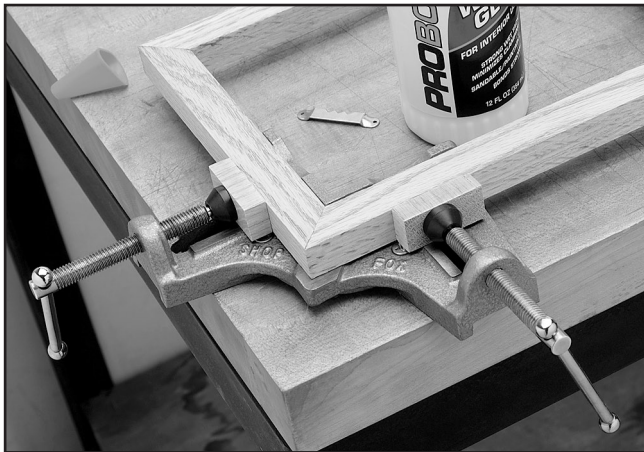

Figure 30. Shop Fox 90° Corner Clamps.

G4955—Bessey® High Torque Band Clamp
G5882—Angle Clips for Band Clamps

The Bandspanner high-torque clamping system combines four adjustable angle corner brackets with a powerful tensioner for precise pressure on square, rectangular, circular and multi-angled objects. A retractable 7 meter polyester band offers exceptional clamping power.



Figure 31. Bessey® High Torque Band Clamp.

Call 1-800-523-4777 To Order

G3326—Bessey® Angle Clamp 3"

Excellent for cabinetmaking, furniture assembly, and framing, these clamps are designed to consistently hold and secure stock at a 90° angle. Clamps uneven thicknesses.

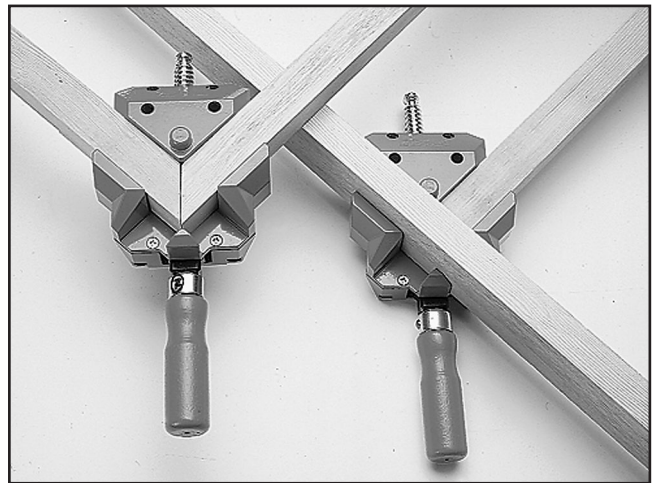

Figure 32. Bessey® Angle Clamp.

H8888—Kreg™ Framing Table

Assembling frames in a production setting has never been easier thanks to our pneumatic clamping table. This table simplifies the assembly process and provides all skill levels the ability to produce consistently flush frames. This table features a large, 4' x 8' work surface tilted at a 30° angle from vertical which allows workpieces to easily fall by gravity into alignment without taking up a lot of space. The squaring fence down the left hand side of the table can be quickly retracted to allow assembly of frames longer than 8'. Four high-quality clamping cylinders glide up and down the transfer arm and can be fired either independently or in unison with the flip of a toggle switch.



Figure 33. Kreg™ Framing Table.



SECTION 6: MAINTENANCE



Schedule

For optimum performance from your machine, follow this maintenance schedule and refer to any specific instructions given in this section.

Daily:

- Check/tighten/replace loose or worn mounting bolts.
- Check/sharpen/replace damaged or dull saw blades.
- Check/repair/replace worn or damaged wires or connectors.
- Check/re-fill pneumatic and lower pivot arm oil reservoirs.
- Clean/protect saw blades and table.
- Check/repair any other unsafe condition.

Weekly:

- Drain water from the air filter collection cup.
- Clean/vacuum inside cabinet stand, and under safety hood.
- Lubricate blade arbor housings and tie-rod pivot points.

Monthly:

- Check/re-tension/replace V-belt tension, damage, or wear.

Cleaning

Vacuum excess wood chips and sawdust, and wipe off the remaining dust with a dry cloth. If any resin has built up, use a resin dissolving cleaner like OxiSolv® spray to remove it (see **Section 5: Accessories** on **Page 23** for more details).

Protect the unpainted cast iron surfaces on the table by wiping the it clean after every use—this ensures moisture from wood dust does not remain on bare metal surfaces.

Keep tables rust-free with regular applications of products like G96® Gun Treatment, SLIPIT®, or Boeshield® T-9 (see **Page 24** for more details).



Lubrication

For the many moving parts of the Model G0641, there are three lubrication systems: 1) the pneumatic oiler attached to the air regulator-lubricator, 2) the lower pivot arm automatic oil system, and 3) manual lubrication of the arbor housings and remaining pivot points.

The pneumatic oiler injects lubrication into the air system as it is used to keep the main and hold-down pneumatic rams moving smoothly.

To lubricate the pneumatic system:

1. DISCONNECT SAW FROM AIR SUPPLY!
2. Fill the oil reservoir with ISO-VG32 tool oil (see **Figure 34**).

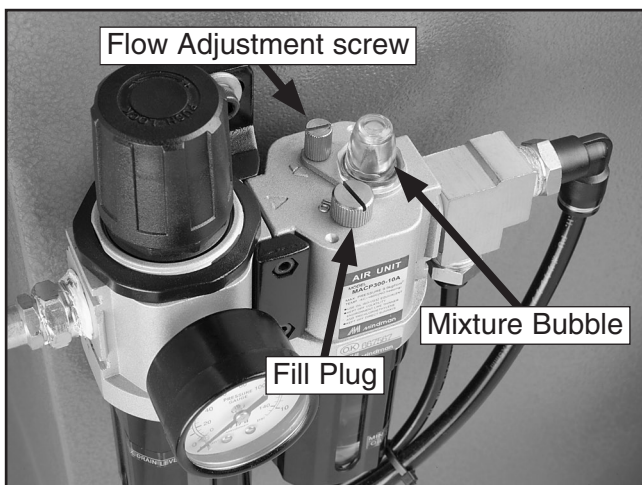

Figure 34. Pneumatic oiler.

3. Tighten the flow adjustment screw clockwise until it stops, then open it ½ turn.

Note: *The goal is to inject enough lubrication into the air system to keep a very light coat of oil on the surface of the rams during operation.*

The lower pivot arm oil system is adjusted so that an adequate flow of lubricant moves through the oil lines to the sides of the lower pivot arms.

To lubricate the lower pivot arms:

1. Slide the fill plate aside to add ISO-VG32 tool oil to the reservoir (see **Figure 35**).

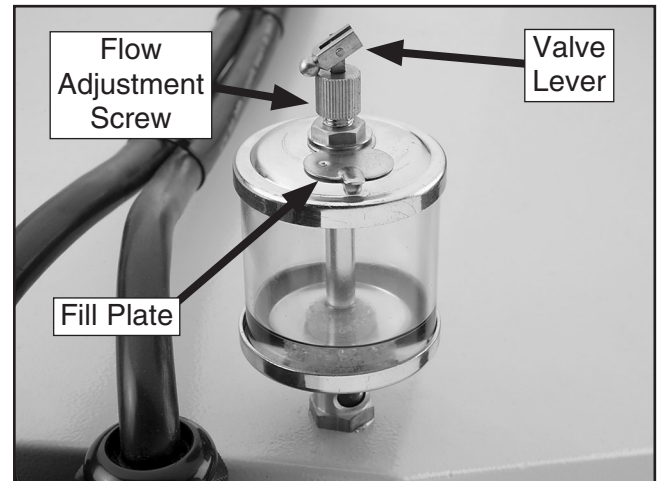

Figure 35. Lower pivot arm oil reservoir.

2. Turn the flow adjustment screw counterclockwise to increase the flow rate of lubricant.
3. Flip the valve lever up, as shown in **Figure 35**, to start the flow of lubricant from the bottom of the reservoir into the oil line.

Note: *We recommend a setting of one drop per 20 pivot arm cycles. Have an assistant count the drops while you cycle the blades lowering and raising to reach this setting.*

4. Flip the valve levers down to close off the flow of lubricant when the machine is not in use.

NOTICE

Failure to perform proper lubrication maintenance on this machine will lead to premature wear of the moving parts, and will void the warranty.



Manual lubrication is required for: 1) blade arbor housings, 2) tie-rod pivot points, and 3) the upper pivot point of the main pneumatic ram.

To lubricate the blade arbor housings:

1. DISCONNECT SAW FROM POWER!
2. DISCONNECT SAW FROM AIR SUPPLY!
3. Raise the front guard up, remove the inner blade guard and blades to access the pivot arm assemblies (see **Figure 36**).

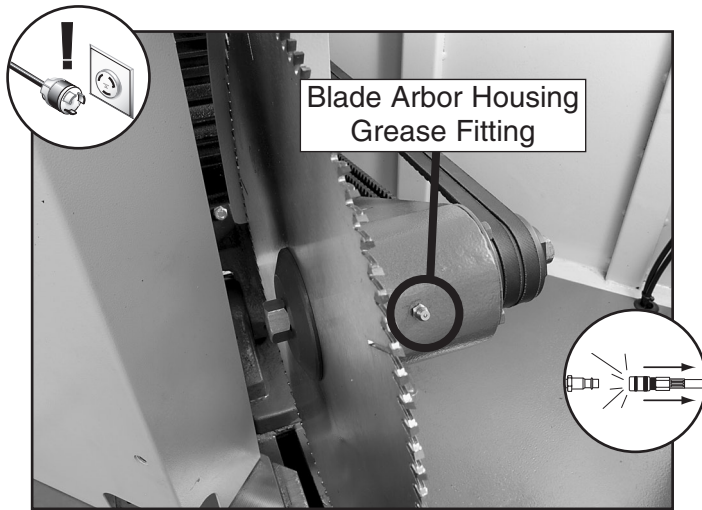

Figure 36. Blade arbor housing grease fitting (left side shown).

4. Clean off the arbor grease fittings, then use a grease gun to add one or two pumps of multi-purpose grease to the arbor housing grease fittings.
5. Re-install the inner blade guard and blades, then lower and secure the front guard before continuing operation.

NOTICE

Adding more than one or two pumps to the arbor housing may cause damage to the seals and require replacement.

To lubricate the tie-rod pivot points:

1. DISCONNECT SAW FROM POWER!
2. DISCONNECT SAW FROM AIR SUPPLY!

3. Raise the front guard up, and remove the inner blade guard and blades to access the tie-rods (see **Figure 37**).

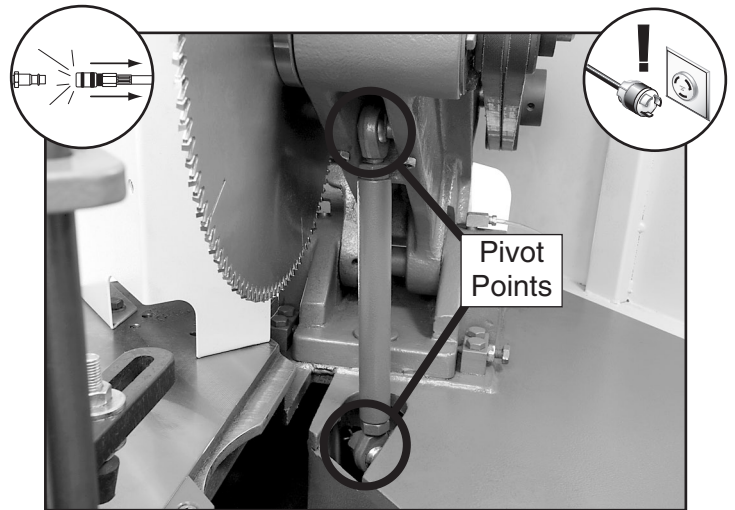

Figure 37. Tie-rod pivot points (one side shown).

4. Brush a small amount of multi-purpose grease on and around the tie-rod pivot points.
5. Re-install the inner blade guard and blades, then lower and secure the front guard before continuing operation.

To lubricate the main ram pivot point:

1. DISCONNECT SAW FROM POWER!
2. Remove the rear cabinet access panel.
3. Brush a small amount of multi-purpose grease on and around the main ram pivot point (see **Figure 38**).

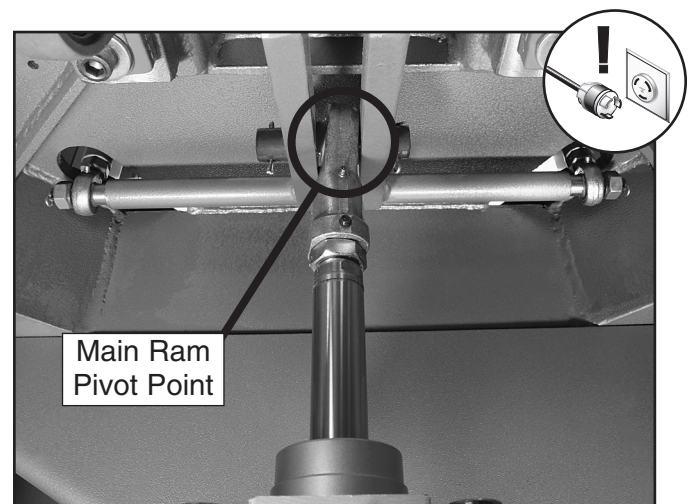

Figure 38. Main pneumatic ram pivot point (shown through the rear cabinet access).



V-Belt Maintenance

With extended use, V-belts will stretch and may slip on the pulleys. When this happens, they need to be re-tensioned. If the V-belts are excessively worn, cracked, or damaged, they need to be replaced. Both processes require similar steps.

To re-tension/replace the V-belts:

1. DISCONNECT SAW FROM POWER!
2. Raise the front guard up, and remove the inner blade guard to access the pivot arm assemblies and motors (see **Figure 39**).

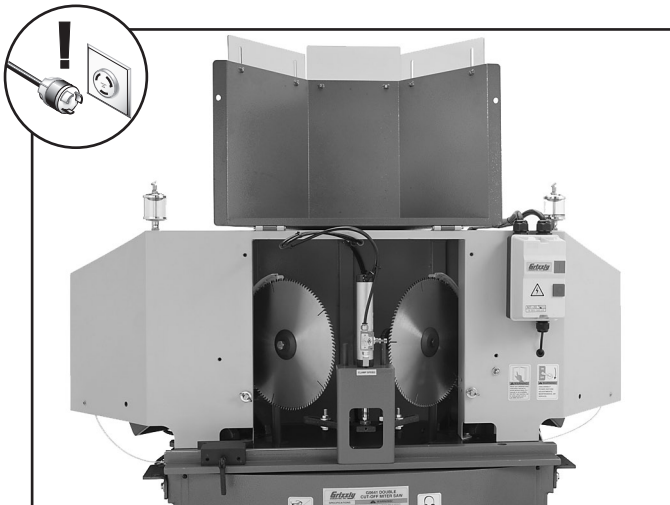
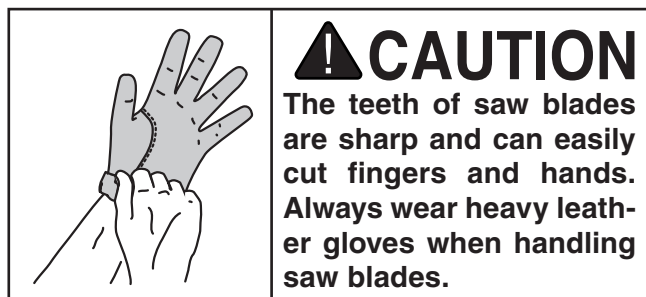

Figure 39. Guards removed to access pivot arm assemblies and motors.



3. Use a 14mm wrench on the inner arbor nut (see **Figure 40**) and a 19mm wrench on the arbor bolt to remove the arbor bolt, arbor flange, and saw blade.

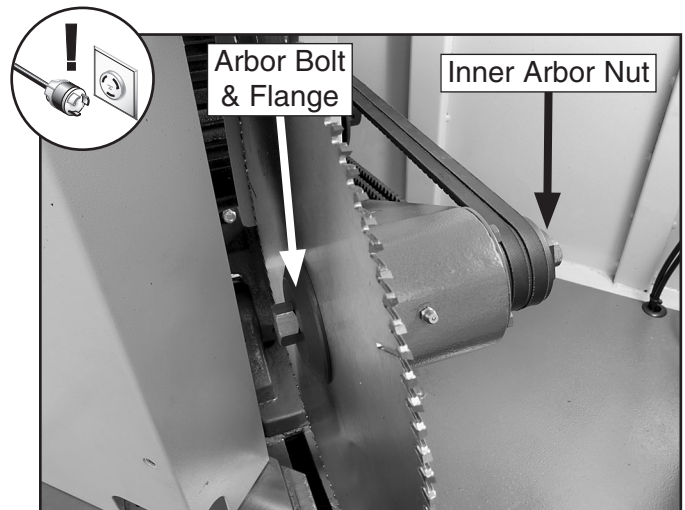

Figure 40. Blade arbor bolt, flange, and nut (left side shown).

Note: The left saw blade has a left-hand arbor bolt—to remove it, turn it clockwise. The right saw blade has a normally threaded arbor bolt and is removed by turning counterclockwise.

4. Use a 10mm hex wrench to remove the two cap screws, lock washers, and the side blade guard (see **Figure 41**).

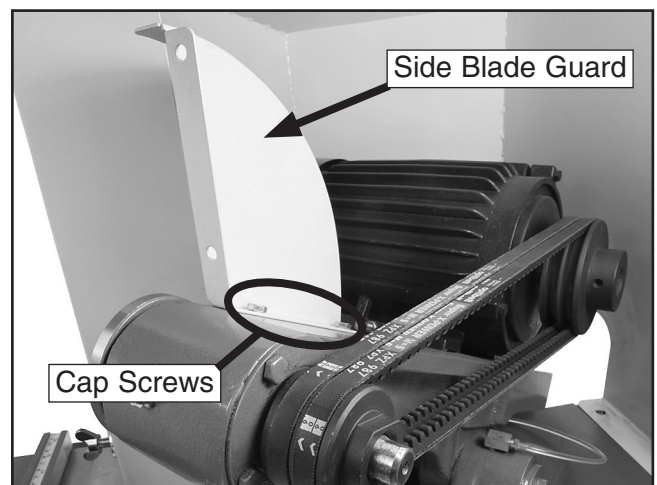

Figure 41. Side blade guard and cap screws.



- Use a 13mm wrench to loosen the two rear motor mounting bolts (see **Figure 42**).

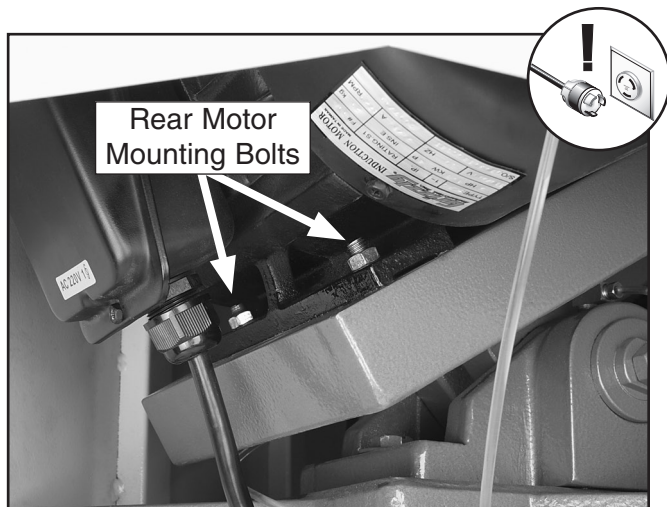

Figure 42. Rear motor mounting bolts.

- Use a 13mm wrench to loosen the front motor mount hex bolt (see **Figure 43**).

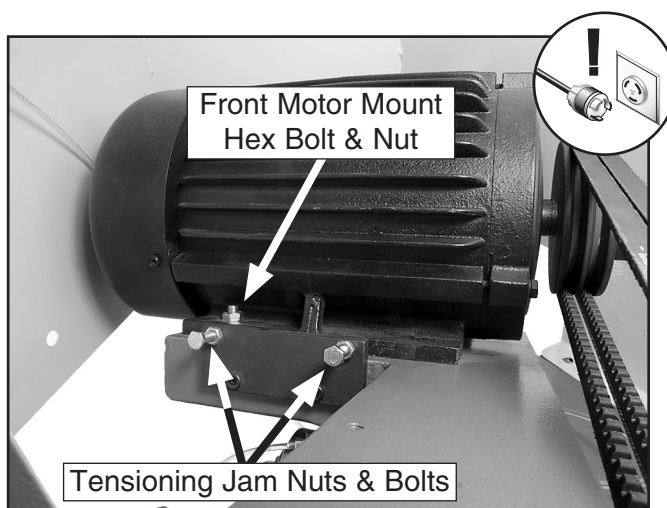

Figure 43. V-belt tensioning bolts.

- Use a 10mm wrench to loosen the tensioning jam nuts and bolts.
- Pull the motor toward the front of the machine to the relieve tension on the V-belts.

- Inspect the V-belts.

—If the V-belts are excessively worn, cracked, or damaged, replace them by rolling them off the pulleys and installing a new matched set.

Note: Replacing the V-belts with a matched set of two ensures that they will transfer power evenly and efficiently.

- Move the motor rearward by tightening the tensioning bolts evenly until there is approximately $\frac{3}{4}$ " deflection of the V-belts between the pulleys when moderate pressure is applied (see **Figure 44**).

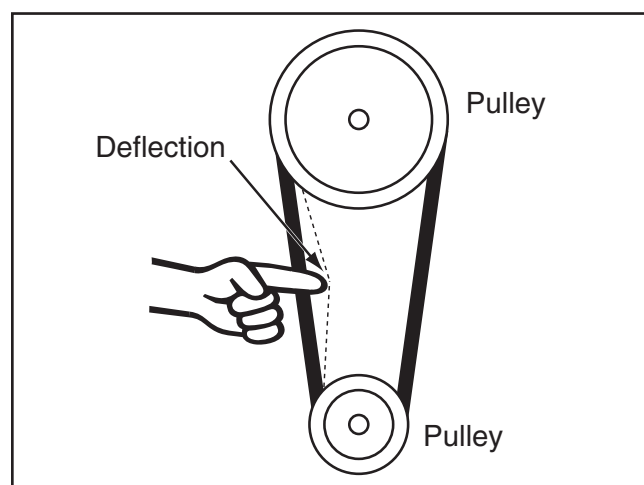

Figure 44. Checking for correct V-belt deflection.

- When you are satisfied with the V-belt tension, re-tighten the tensioning jam nuts.
- Re-tighten the motor mounting bolts.
- Re-install the side blade guard and the saw blade.

Note: The arbor flange **MUST** be installed to ensure the blade is safely secure.

- Re-install the inner blade guard and secure the front guard in the lower position.



SECTION 7: SERVICE

Review the troubleshooting and procedures in this section to fix or adjust your machine if a problem develops. If you need replacement parts or you are unsure of your repair skills, then feel free to call our Technical Support at (570) 546-9663.

Troubleshooting

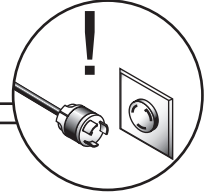

Motor & Electrical

Symptom	Possible Cause	Possible Solution
Machine does not start or a breaker trips.	<ol style="list-style-type: none"> 1. Front guard safety switch dis-engaged/at fault. 2. Plug/receptacle is at fault or wired incorrectly. 3. Start capacitor is at fault. 4. Motor connection wired incorrectly. 5. Wall fuse/circuit breaker is blown/tripped. 6. Thermal overload relay has tripped. 7. Contactor not getting energized/has burnt contacts. 8. Power supply switched OFF or is at fault. 9. Wiring is open/has high resistance. 10. Motor ON/OFF switch is at fault. 11. Centrifugal switch is at fault. 12. Motor is at fault. 	<ol style="list-style-type: none"> 1. Secure front guard to the down working position; replace faulty safety switch. 2. Test for good contacts; correct the wiring. 3. Test/replace if faulty. 4. Correct motor wiring connections. 5. Ensure circuit size is suitable for this machine; replace weak breaker. 6. Turn cut-out dial to increase working amps and push the reset pin. Replace if tripped multiple times (weak relay). 7. Test for power on all legs and contactor operation. Replace unit if faulty. 8. Ensure power supply is switched on; ensure power supply has the correct voltage. 9. Check for broken wires or disconnected/corroded connections, and repair/replace as necessary. 10. Replace faulty ON/OFF switch. 11. Adjust/replace the centrifugal switch if available. 12. Test/repair/replace.
Machine stalls or is overloaded.	<ol style="list-style-type: none"> 1. Workpiece material is not suitable for this machine. 2. Hold-downs are not holding workpiece in place; workpiece moves during operation. 3. Machine is undersized for the task. 4. Run capacitor is at fault. 5. Motor connection is wired incorrectly. 6. V-belts slipping. 7. Plug/receptacle is at fault. 8. Pulley/sprocket slipping on shaft. 9. Motor bearings are at fault. 10. Motor has overheated. 11. Contactor not getting energized or has poor contacts. 12. Motor is at fault. 	<ol style="list-style-type: none"> 1. Only cut wood products; make sure moisture content is below 20% and there are no foreign materials in the workpiece. 2. Properly adjust hold-downs to workpiece; adjust lowering speeds so that hold-downs clamp workpiece before blades begin the cut (Pages 19 & 20). 3. Use sharp blade; reduce blade lowering speed. 4. Test/repair/replace. 5. Correct motor wiring connections. 6. Replace bad V-belts as a matched set, and re-tension (Page 29). 7. Test for good contacts; correct the wiring. 8. Replace loose pulley/shaft. 9. Test by rotating shaft; rotational grinding/loose shaft requires bearing replacement. 10. Clean off motor, let cool, and reduce workload. 11. Test for power on all legs and contactor operation. Replace if faulty. 12. Test/repair/replace.



Motor & Electrical (continued)

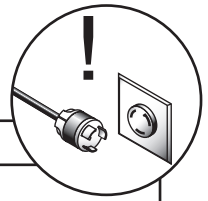

Symptom	Possible Cause	Possible Solution
Machine has vibration or noisy operation.	<ol style="list-style-type: none"> 1. Motor or component is loose. 2. Blade is at fault. 3. V-belts worn or loose. 4. Pulley is loose. 5. Motor mount loose/broken. 6. Machine is incorrectly mounted or sits unevenly. 7. Arbor pulley is loose. 8. Motor fan is rubbing on fan cover. 9. Arbor bearings are at fault. 10. Motor bearings are at fault. 	<ol style="list-style-type: none"> 1. Inspect/replace stripped or damaged bolts/nuts, and re-tighten with thread locking fluid. 2. Tighten arbor bolt; replace warped, bent, or twisted blade; resharpen dull blade. 3. Inspect/replace V-belts with a new matched set (Page 29). 4. Re-align/replace shaft, pulley, setscrew, and key as required. 5. Tighten/replace. 6. Tighten/replace anchor studs in floor; relocate/shim machine. 7. Re-tighten/replace arbor pulley with shaft and thread locking liquid. 8. Replace dented fan cover; replace loose/damaged fan. 9. Replace arbor housing bearings; replace arbor. 10. Test by rotating shaft; rotational grinding/loose shaft requires bearing replacement.

Miter Saw Operations

Symptom	Possible Cause	Possible Solution
Blade is not aligned with table miter slot.	<ol style="list-style-type: none"> 1. Blade is warped. 2. Pivot arm assembly out of alignment. 	<ol style="list-style-type: none"> 1. Replace blade. 2. Adjust pivot arm assembly 45° to fence (Page 34).
Machine slows when operating.	<ol style="list-style-type: none"> 1. Applying too much pressure to workpiece. 2. V-belts loose or worn. 	<ol style="list-style-type: none"> 1. Reduce blade lowering speed (Page 20). 2. Re-tension/replace V-belts (Page 29).
Excessive vibration.	<ol style="list-style-type: none"> 1. Loose arbor nut. 2. Blade out of balance. 3. Arbor bearings worn. 	<ol style="list-style-type: none"> 1. Tighten the arbor bolt. 2. Replace blade. 3. Replace arbor bearings.
Board binds or burns cuts.	<ol style="list-style-type: none"> 1. Blade is warped. 2. Dull blade. 3. Feed rate too slow. 	<ol style="list-style-type: none"> 1. Replace blade. 2. Sharpen/replace blade. 3. Increase blade lowering/raising speed (Page 20).
Workpiece moves during cutting.	<ol style="list-style-type: none"> 1. Hold-downs are not properly adjusted. 2. Blades begin cut before hold-downs clamp workpiece. 	<ol style="list-style-type: none"> 1. Properly adjust hold-downs to workpiece (Page 19). 2. Adjust lowering speeds so that hold-downs clamp workpiece before blades begin the cut (Page 20).
Cuts are not 45°.	<ol style="list-style-type: none"> 1. Blade is warped. 2. Pivot arm assembly out of alignment. 	<ol style="list-style-type: none"> 1. Replace blade. 2. Adjust pivot arm assembly 45° with fence (Page 34).
Excessive or unacceptable tear out.	<ol style="list-style-type: none"> 1. Incorrect blade being used. 2. Dull blade. 3. Bakelite inserts or aluminum block in table have been cut larger excessively larger than blade kerf. 4. Blade lowering/raising speeds incorrect for workpiece material. 	<ol style="list-style-type: none"> 1. Use 12" blades that are designed for miter cutting of wood products that typically have a high tooth count and a #6 tooth set. 2. Sharpen/replace blade. 3. Replace bakelite inserts (Part No. 135 & 135) or aluminum block (Part No. 134) (see Page 41). 4. Adjust blade lowering/raising speeds while making test cuts on scrap piece of same material to be used for production run, using trial-and-error adjustments.



Pneumatic System

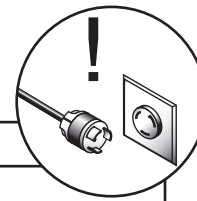

Symptom	Possible Cause	Possible Solution
Hold-downs/blade pivot arms not responding.	<ol style="list-style-type: none"> 1. Air pressure not adequate. 2. Air regulator-lubricator or internal regulator at fault. 3. Hold-down/main air cylinder at fault. 4. Hold-down/blade speed valve(s) at fault. 5. Air line pinched/clogged. 6. Sub/master valve is at fault. 7. Foot pedal actuator at fault. 	<ol style="list-style-type: none"> 1. Connect machine to an air supply of 70–90 PSI; adjust air regulator-lubricator and internal air regulator to 70 PSI. 2. Test/replace; adjust to 70 PSI. 3. Test/replace. 4. Test/replace. 5. Use Pneumatic System Diagram (Page 38) to trace air flow; check for pinched/clogged air line and air flow at connections; clean/repair/replace as needed. 6. Test/clean/replace. 7. Test/clean/replace.
Hold-downs not securing workpiece when cutting.	<ol style="list-style-type: none"> 1. Hold-downs not properly adjusted. 2. Hold-downs not completely lowering before blades begin cut. 3. Hold-down neoprene tips glazed or worn. 	<ol style="list-style-type: none"> 1. Properly adjust hold-downs for workpiece (Page 19). 2. Correctly adjust hold-down and blade lowering speeds (Page 20). 3. Re-dress hold-down tips with fine grit sandpaper; replace.
Hold-downs not raising after cut.	<ol style="list-style-type: none"> 1. Pneumatic limit switch at fault. 2. Master or sub-valve at fault. 	<ol style="list-style-type: none"> 1. Reposition/test/replace limit switch (Page 35). 2. Test/replace.
Blade pivot arms not raising after cut.	<ol style="list-style-type: none"> 1. Master or sub-valve at fault. 2. Foot pedal actuator at fault. 	<ol style="list-style-type: none"> 1. Test/replace. 2. Test/replace.



Aligning Pivot Arm Assembly

The pivot arm assembly is aligned at the factory to be precisely 45° from the fence. This setting should never need to be changed or adjusted.

If your cuts are not precisely 45°, do the following before performing this procedure:

- Check the saw blades for warping or bent teeth—replace if necessary (**Page 22**).
- Make sure the hold-downs firmly clamp the workpiece to the fence before the blades begin the cut (**Pages 19 & 20**).
- Remove any resin build-up or debris from the table, fence, and fence stop.

To realign the pivot arm assemblies:

1. DISCONNECT SAW FROM POWER!
2. Raise the front guard up, and remove the inner blade guard to access the pivot arm assemblies and motors (see **Figure 45**).

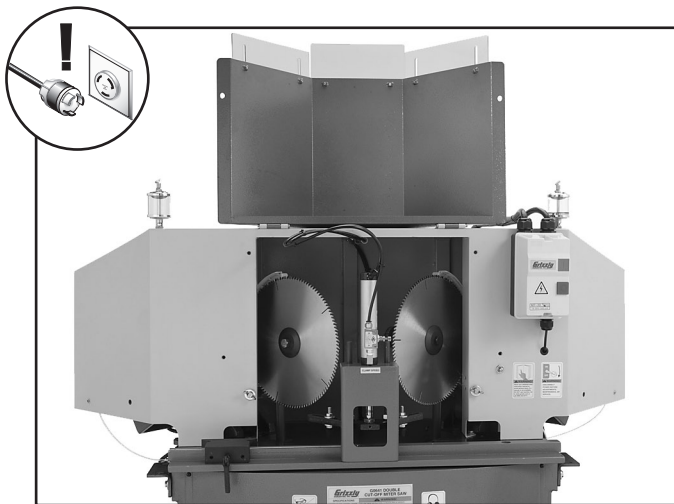

Figure 45. Guards removed to access pivot arm assemblies.

Note: *It is safer and more convenient to remove the saw blade opposite from the pivot arm assembly that you are working on.*

3. Use a 19mm wrench to loosen, but not remove, the front and rear motor base mounting bolts.
4. Use a 13mm wrench to loosen the alignment jam nuts on either side of the motor base (see **Figure 46**).

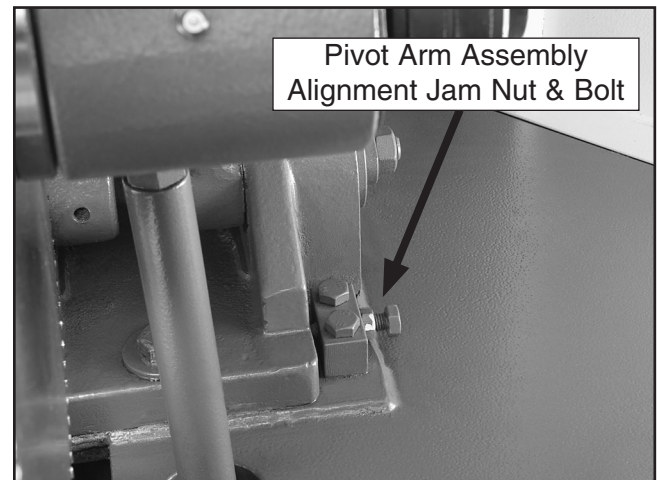

Figure 46. Pivot arm assembly alignment bolt.

5. With the machine still disconnected from power and your hands away from the blades, press the foot pedal actuator to bring the blades down and into the miter slots.

Continued on next page →



6. Place a 45° square against the fence and the blade, as shown in **Figure 47**.

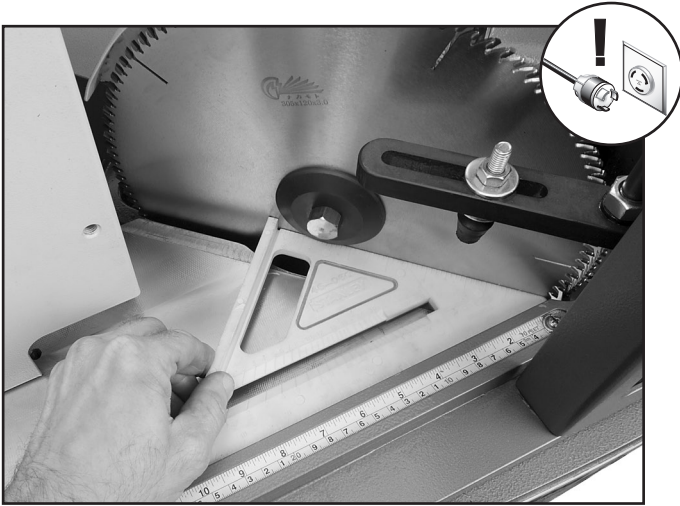

Figure 47. Using a 45° square to align blade.

7. Loosen the aligning bolt on one side and tighten the one on the other to move the angle of the blade so that it is precisely 45° to the fence.
8. Lift your foot from the pedal actuator to raise the blades, then re-tighten the aligning jam nuts and both motor mounting bolts to secure the setting.
9. Repeat **Steps 3–8** for the opposite pivot arm assembly if necessary.
10. Reinstall the inner blade guard and secure the front guard in the down position.
11. Make a cut to confirm that the blades cut a 45° angle. Repeat the steps above if necessary.

Pneumatic Limit Switch

The pneumatic limit switch (see **Figure 48**) is activated when the blades and pivot arms raise to their uppermost position. This switch then raises the hold-downs and releases the workpiece.

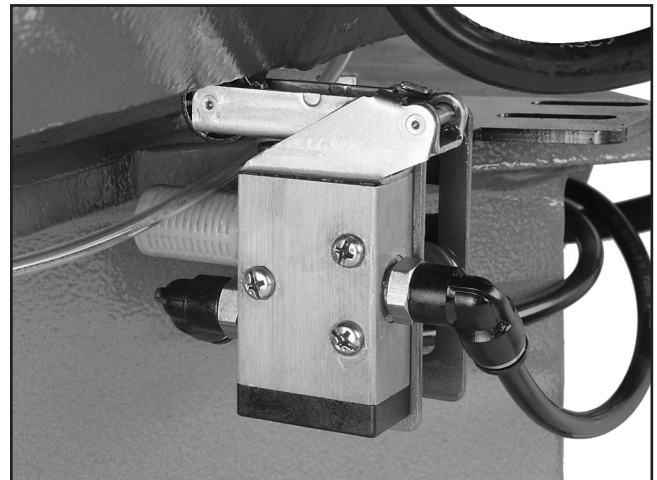



Figure 48. Pneumatic limit switch (right rear of machine).

Generally this switch does not need service or adjustment. However, if necessary to adjust its position on the bracket, make sure that the hold-downs raise up only after the blades have reached their uppermost position.



Electrical Wiring Diagram

**220V
 Single-Phase
 NEMA L6-30
 Plug & Receptacle
 (As Recommended)**

⚠ WARNING!
SHOCK HAZARD!
 Disconnect power
 before working on
 wiring.



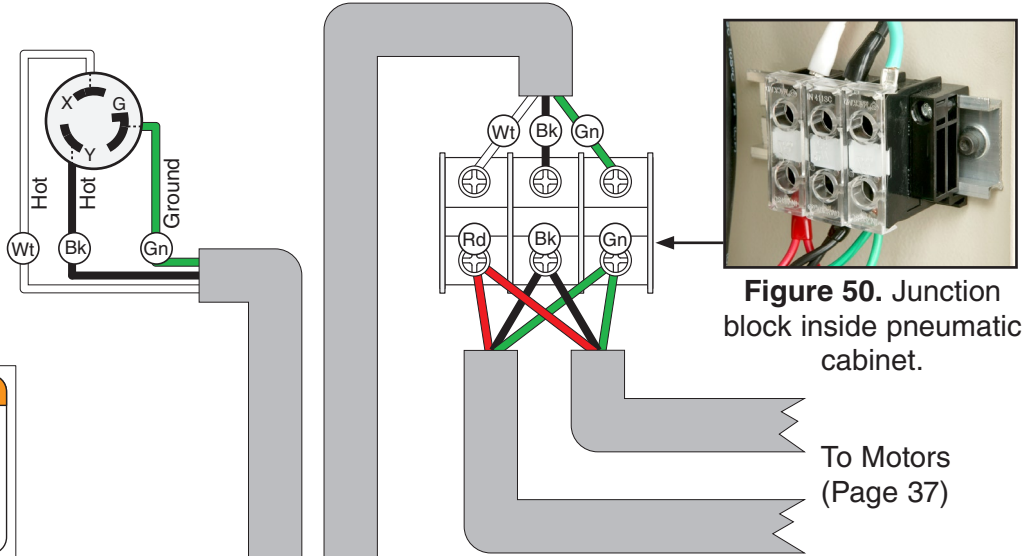
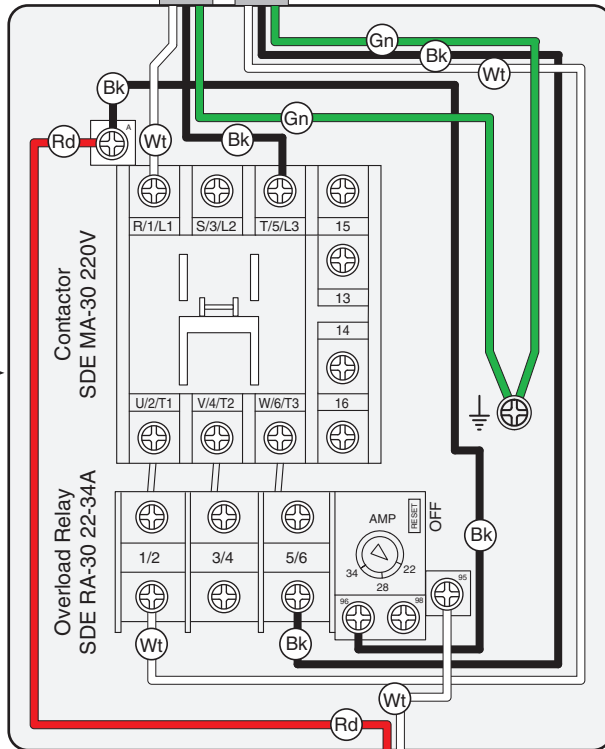

Figure 49. ON/OFF magnetic switch wiring.



Color Key

- Black — Bk —
- White — Wt —
- Red — Rd —
- Green — Gn —

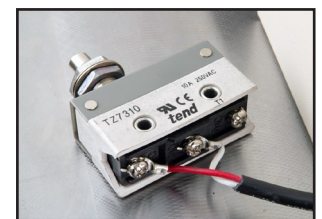
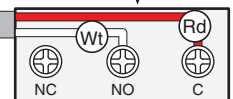

Figure 51. Safety switch wiring.



 View this page in color at www.grizzly.com.



Motor Wiring Diagram

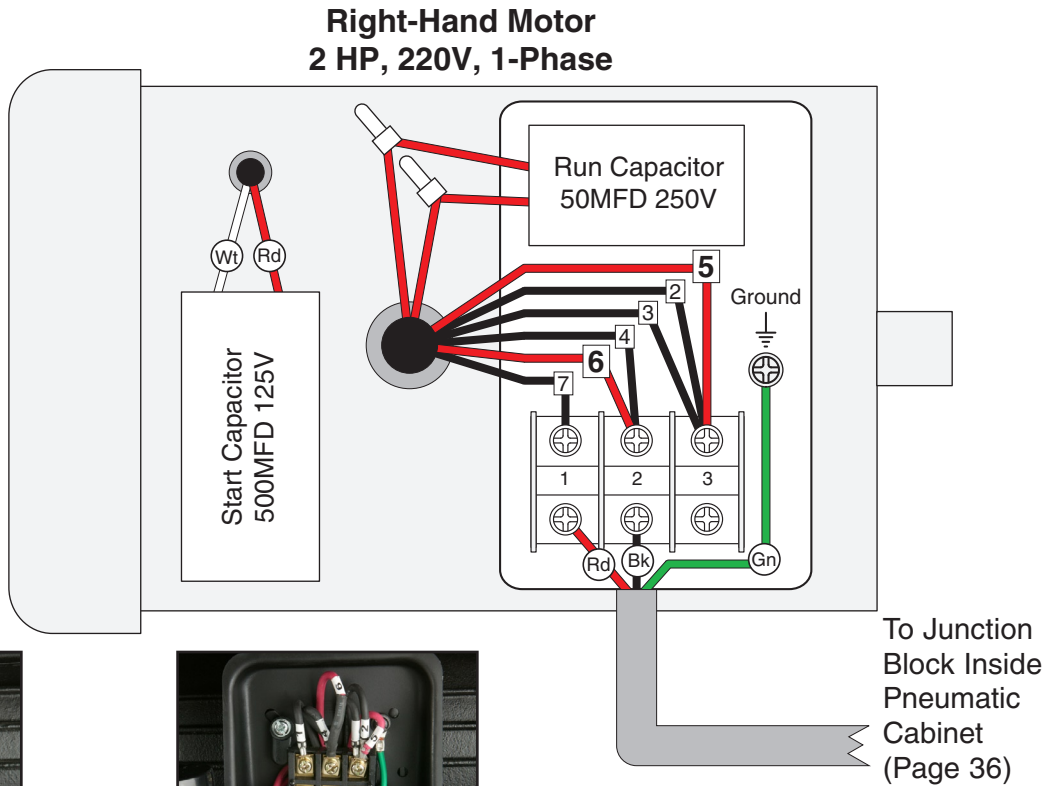
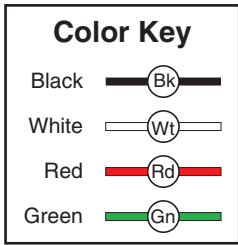

Figure 52. Left-hand motor wiring.

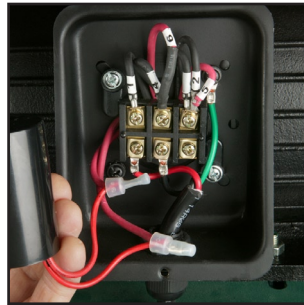

Figure 53. Right-hand motor wiring.

NOTICE

The motor wiring shown here is current at the time of printing, but it may not match your machine. Always use the wiring diagram inside the motor junction box.

MOTOR DIRECTION NOTICE

If motor rotation direction is incorrect, swap wires 5 and 6 inside the motor wiring junction box.

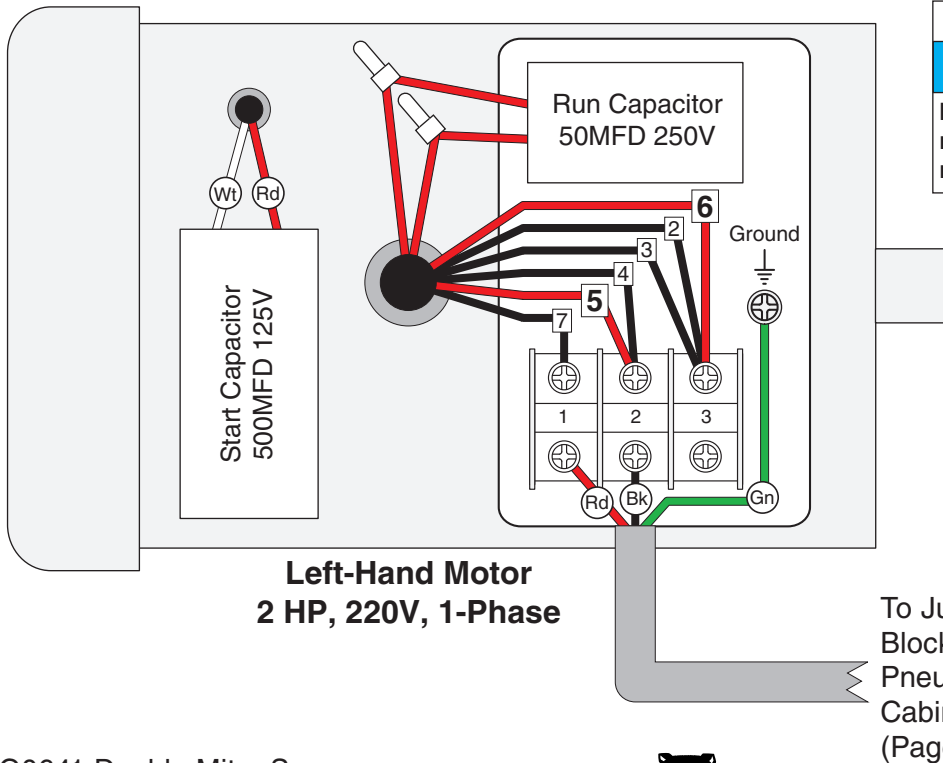

Pneumatic System Diagram

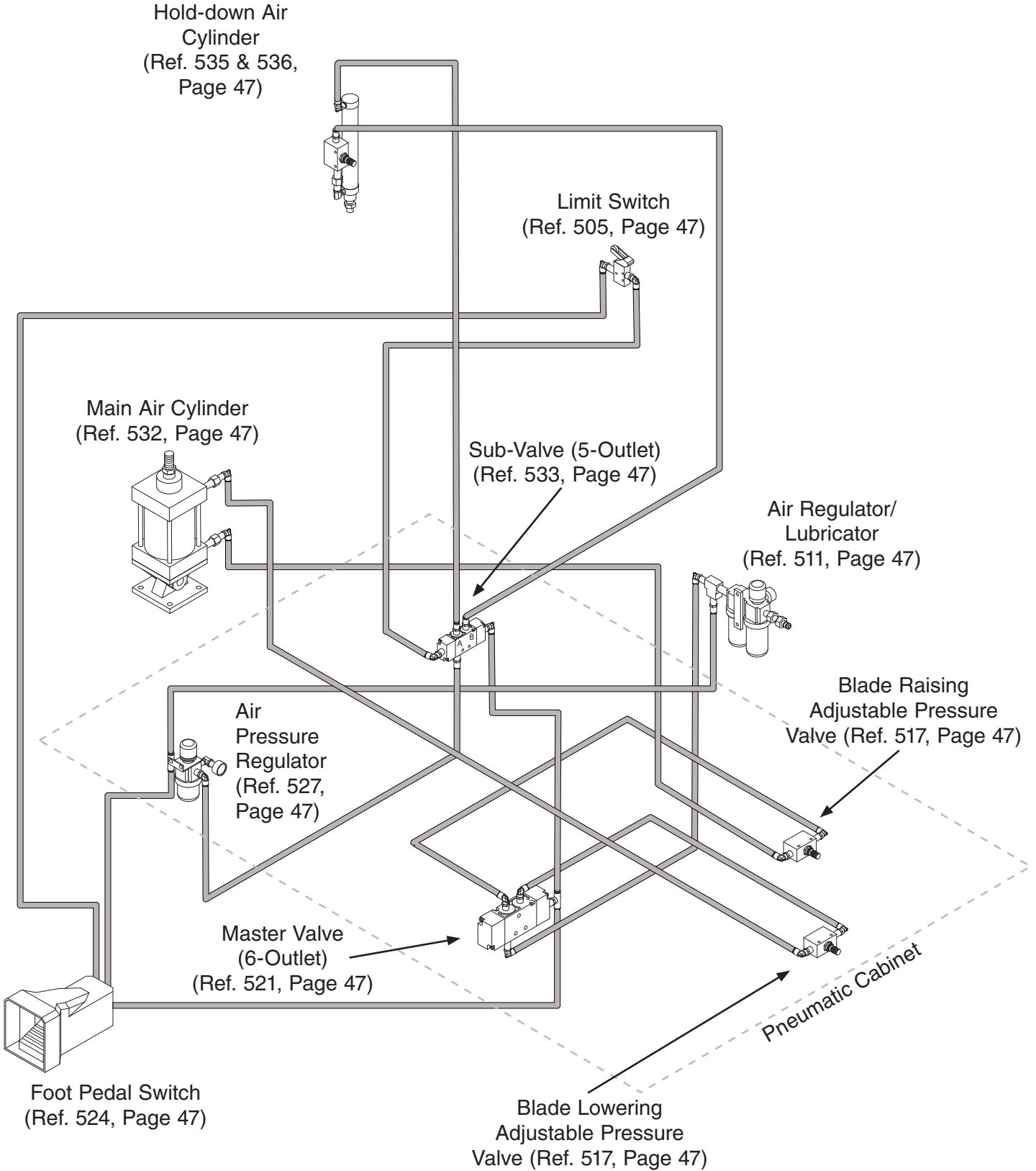

SECTION 8: PARTS

Cabinet Breakdown

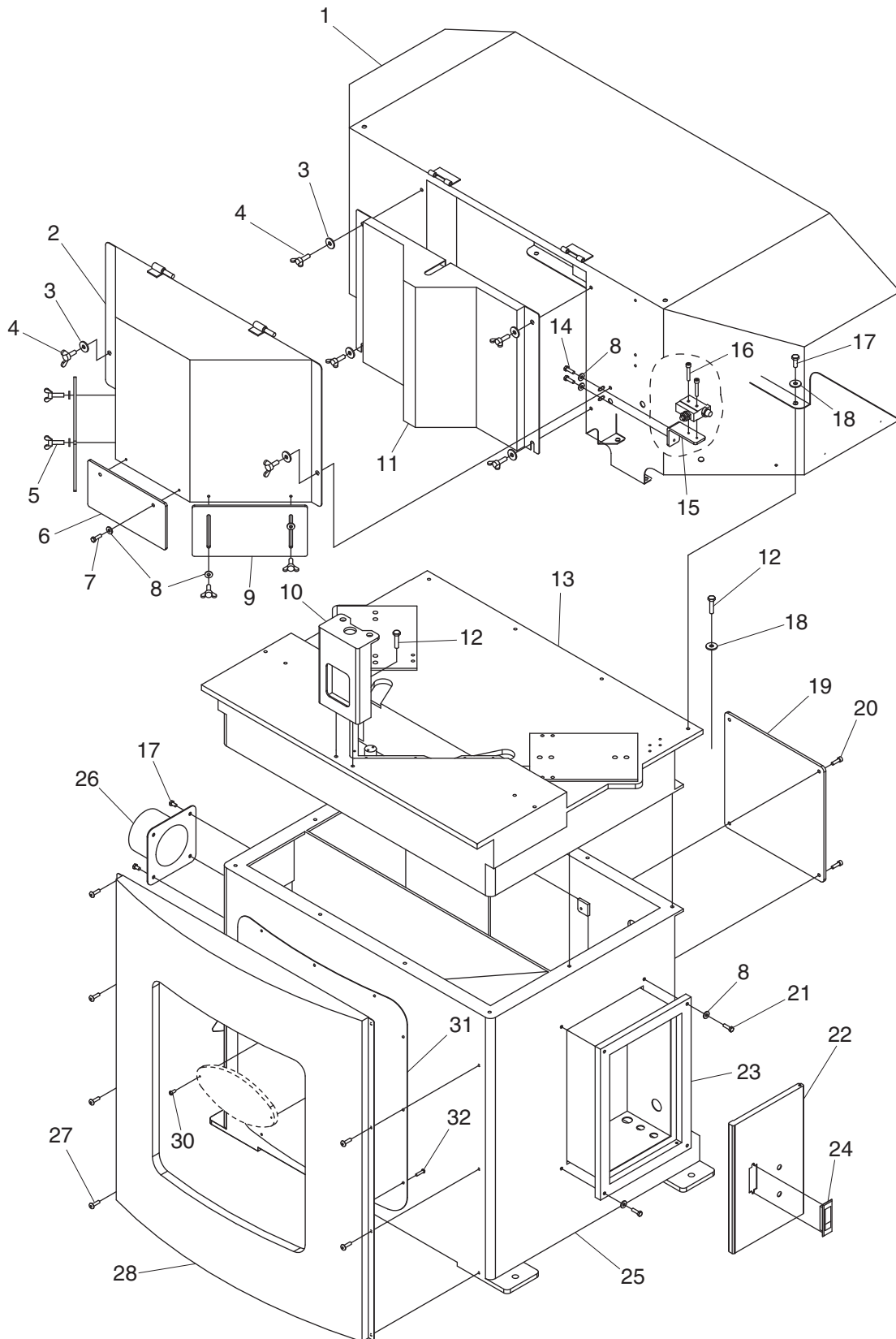

Cabinet Parts List

REF	PART #	DESCRIPTION
1	P0641001	SAFETY HOOD
2	P0641002	FRONT GUARD
3	PW01M	FLAT WASHER 8MM
4	P0641004	WING SCREW M8-1.25 X 20
5	P0641005	WING SCREW M6-1 X 16
6	P0641006	TRANSPARENT GUARD CENTER
7	PB83M	HEX BOLT M6-1 X 16
8	PW03M	FLAT WASHER 6MM
9	P0641009	TRANSPARENT GUARD SIDE
10	P0641010	HOLD-DOWN BRACKET
11	P0641011	INNER GUARD
12	PB09M	HEX BOLT M8-1.25 X 20
13	P0641013	TABLE
14	PB02M	HEX BOLT M6-1 X 12
15	P0641015	PNEUMATIC SWITCH BRACKET
16	PSB162M	CAP SCREW M4-.7 X 25

REF	PART #	DESCRIPTION
17	PB03M	HEX BOLT M8-1.25 X 16
18	PW01M	FLAT WASHER 8MM
19	P6144019	CABINET ACCESS PANEL
20	PSB11M	CAP SCREW M8-1.25 X 16
21	PB10M	HEX BOLT M6-1 X 25
22	P0641022	PNEUMATIC ACCESS DOOR
23	P0641023	PNEUMATIC CONTROL BOX
24	P0641024	DOOR LATCH
25	P0641025	CABINET
26	P0641026	DUST PORT 4"
27	PSB50M	CAP SCREW M5-.8 X 10
28	P0641028	CABINET FRAME FRONT
30	PS21M	PHLP HD SCR M4-.7 X 15
31	P0641031	CABINET PLATE FRONT
32	PS08M	PHLP HD SCR M5-.8 X 12



Drive System Breakdown

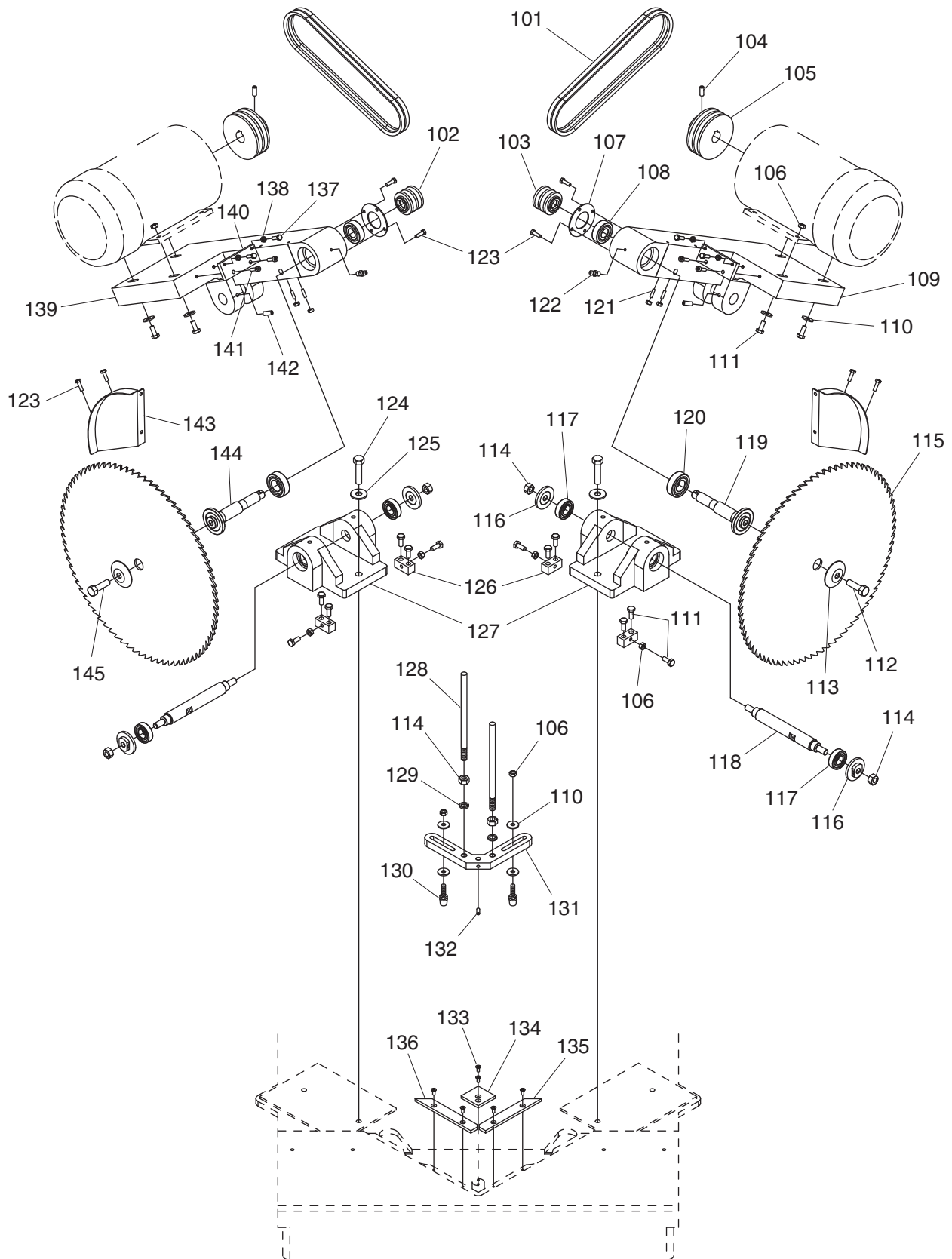

Drive System Parts List

REF	PART #	DESCRIPTION
101	PVM37	V-BELT M-37 3L370
102	P0641102	BLADE PULLEY LEFT
103	P0641103	BLADE PULLEY RIGHT
104	PSS16M	SET SCREW M8-1.25 X 10
105	P0641105	MOTOR PULLEY
106	PN03M	HEX NUT M8-1.25
107	P0641107	BEARING SPACER
108	P6204	BALL BEARING 6204ZZ
109	P0641109	MOTOR BASE RIGHT
110	PW01M	FLAT WASHER 8MM
111	PB20M	HEX BOLT M8-1.25 X 35
112	P0641112	ARBOR BOLT M12-1.75 X 40 RH
113	P0641113	ARBOR FLANGE
114	PN09M	HEX NUT M12-1.75
115	P0641115	SAW BLADE 12" 120TPI
116	P0641116	BEARING SPACER
117	P6004Z	BALL BEARING 6004Z
118	P0641118	PIVOT SHAFT
119	P0641119	ARBOR RIGHT
120	P6205Z	BALL BEARING 6205Z
121	PSS25M	SET SCREW M6-1 X 20
122	P0641122	GREASE FITTINGS M6-1
123	PB83M	HEX BOLT M6-1 X 16

REF	PART #	DESCRIPTION
124	PB24M	HEX BOLT M12-1.75 X 45
125	PW06M	FLAT WASHER 12MM
126	P0641126	THREADED BLOCK
127	P0641127	PIVOT BRACKET
128	P0641128	HOLD-DOWN ROD
129	PLW05M	LOCK WASHER 12MM
130	P0641130	HOLD-DOWN NEOPRENE TIP
131	P0641131	HOLD-DOWN BRACE
132	PSS01M	SET SCREW M6-1 X 10
133	PFH01M	FLAT HD SCR M5-.8 X 15
134	P0641134	ALUMINUM BLOCK
135	P0641135	BAKELITE INSERT RIGHT
136	P0641136	BAKELITE INSERT LEFT
137	PB29M	HEX BOLT M6-1 X 30
138	PN01M	HEX NUT M6-1
139	P0641139	MOTOR BASE LEFT
140	P0641140	ADJUSTING PLATE
141	PSB02M	CAP SCREW M6-1 X 20
142	PSS09M	SET SCREW M8-1.25 X 20
143	P0641143	BLADE SIDE GUARD
144	P0641144	ARBOR LEFT
145	P0641145	ARBOR BOLT M12-1.75 X 40 LH



Pivot Linkage Breakdown & Parts List

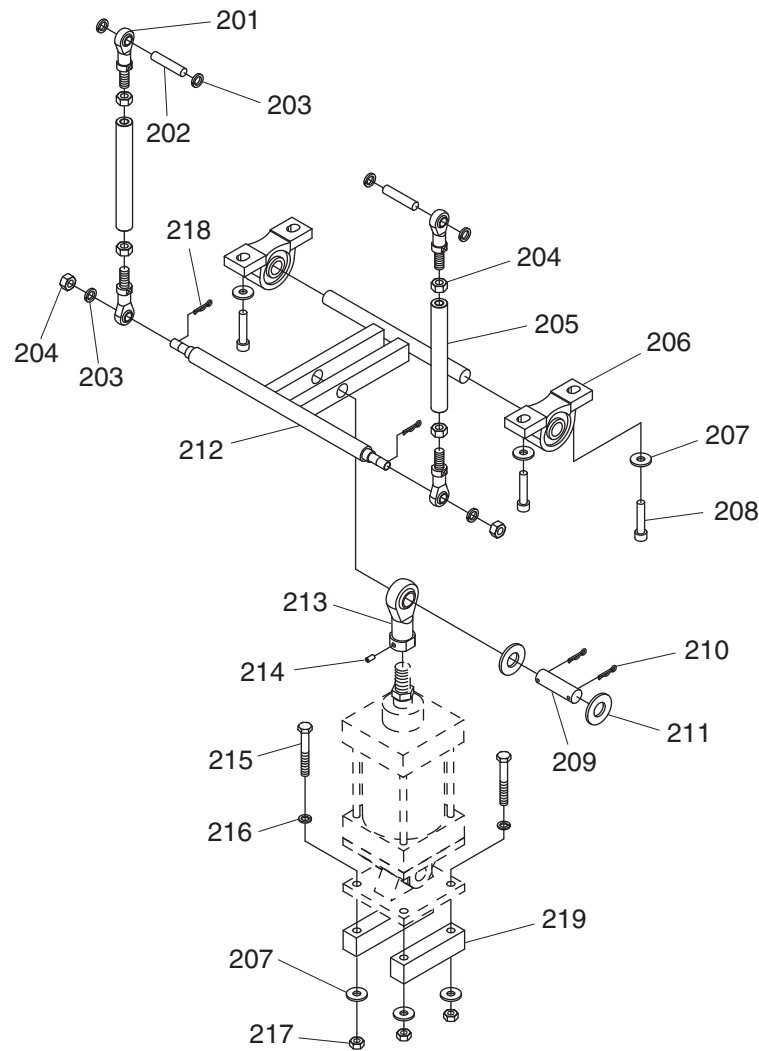

REF	PART #	DESCRIPTION
201	P0641201	TIE-ROD PIVOT BOLT
202	P0641202	SHAFT
203	PLW05M	LOCK WASHER 12MM
204	PN09M	HEX NUT M12-1.75
205	P0641205	TIE-ROD
206	P0641206	PIVOT BRACKET
207	PW04M	FLAT WASHER 10MM
208	PSB84M	CAP SCREW M10-1.5 X 35
209	P0641209	DRILLED HEADLESS CLEVIS PIN
210	P0641210	HAIRPIN COTTER PIN 160MM

REF	PART #	DESCRIPTION
211	PW13M	FLAT WASHER 20MM
212	P0641212	ROCKER ARM
213	P0641213	PIVOT HEAD NUT
214	PSS01M	SET SCREW M6-1 X 10
215	PB120M	HEX BOLT M10-1.5 X 65
216	PLW06M	LOCK WASHER 10MM
217	PN02M	HEX NUT M10-1.5
218	P0641218	HAIRPIN COTTER PIN 80MM
219	P0641219	MOUNTING BLOCK



Extension Wings Breakdown & Parts List

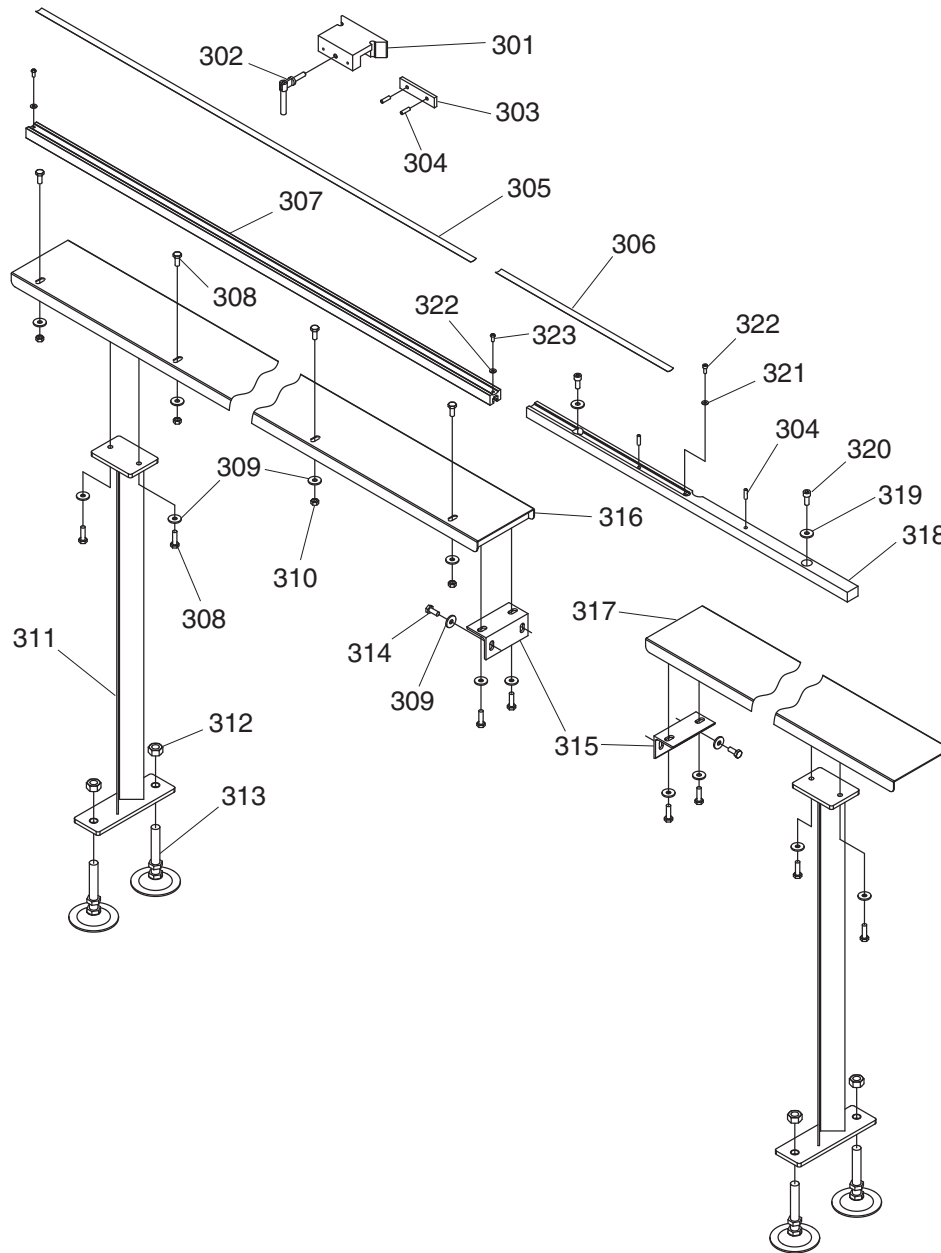

REF	PART #	DESCRIPTION
301	P0641301	FENCE STOP
302	P0641302	LOCK LEVER M8-1.25 X 35
303	P0641303	CLAMP PLATE
304	PRP93M	ROLL PIN 6 X 25
305	P0641305	FENCE SCALE 0" - 16-1/2"
306	P0641306	FENCE SCALE 16-1/2" - 64"
307	P0641307	FENCE RIGHT
308	PB03M	HEX BOLT M8-1.25 X 16
309	PW01M	FLAT WASHER 8MM
310	PN03M	HEX NUT M8-1.25
311	P0641311	SUPPORT LEG
312	PN04	HEX NUT 5/8-11

REF	PART #	DESCRIPTION
313	P0641313	MOUNTING FOOT W/HEX NUTS
314	PB09M	HEX BOLT M8-1.25 X 20
315	P0641315	WING SUPPORT BRACKET
316	P0641316	EXTENSION WING RIGHT
317	P0641317	EXTENSION WING LEFT
318	P0641318	FENCE LEFT
319	PW01M	FLAT WASHER 8MM
320	PSB14M	CAP SCREW M8-1.25 X 20
321	PW02M	FLAT WASHER 5MM
322	PSB33M	CAP SCREW M5-.8 X 12
323	PS08M	PHLP HD SCR M5-.8 X 12



Electrical & Lubrication Systems Breakdown

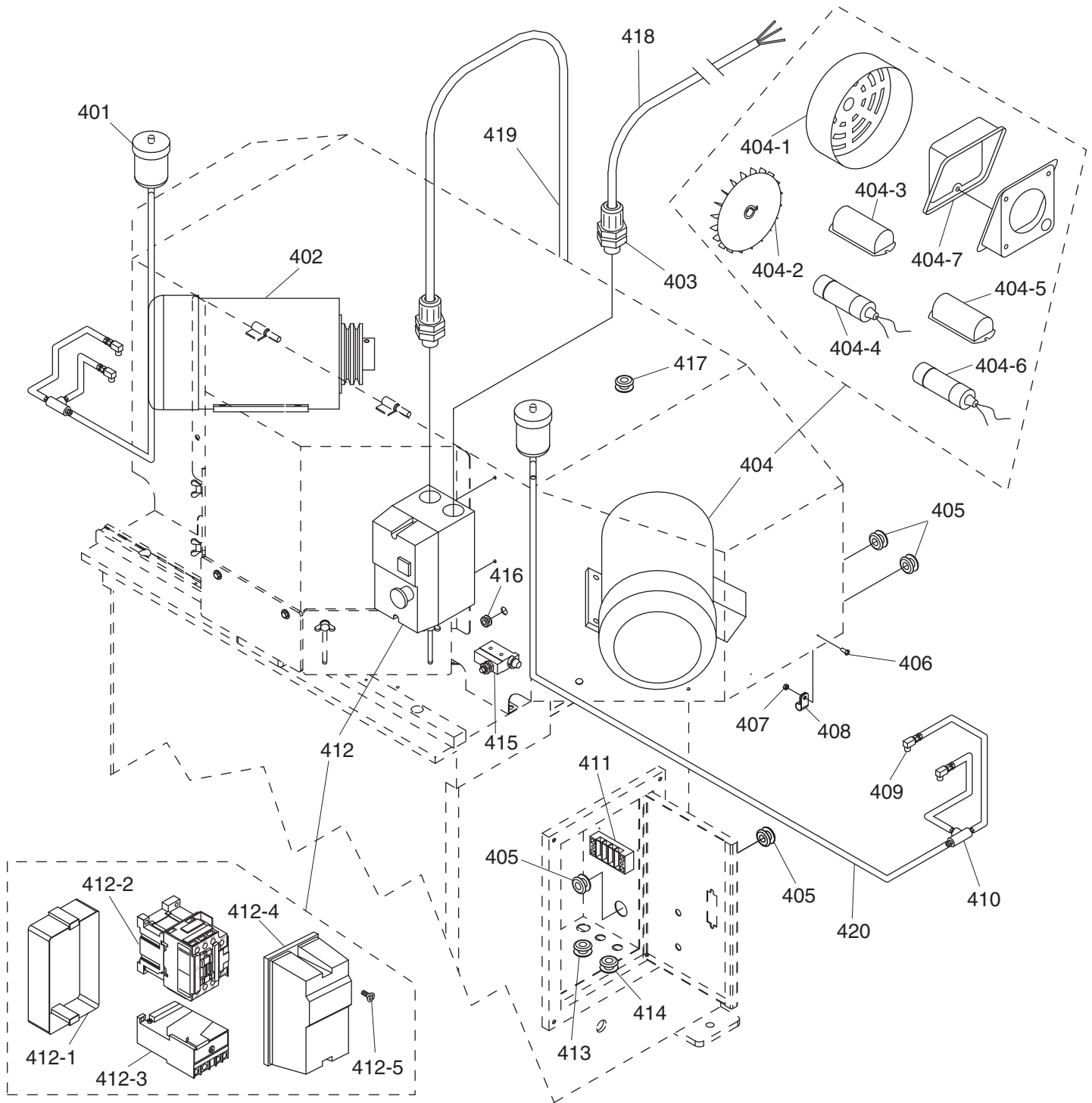

Electrical & Lubrication Systems Parts List

REF	PART #	DESCRIPTION
401	P0641401	OIL RESERVOIR
402	P0641402	MOTOR 2HP 220V 1PH LEFT
403	P0641403	STRAIN RELIEF LARGE
404	P0641404	MOTOR 2HP 220V 1PH RIGHT
404-1	P0641404-1	MOTOR FAN COVER
404-2	P0641404-2	MOTOR FAN
404-3	P0641404-3	S CAPACITOR COVER
404-4	PC500A	S CAPACITOR 500M 125V 1-3/4 X 3-3/4
404-5	P0641404-5	R CAPACITOR COVER
404-6	PC050D	R CAPACITOR 50M 250V 1-1/2 X 2-3/8
404-7	P0641404-7	MOTOR WIRING JUNCTION BOX
405	P0641405	STRAIN RELIEF 27MM
406	PS08M	PHLP HD SCR M5-.8 X 12
407	PN06M	HEX NUT M5-.8
408	P0641408	CABLE CLAMP
409	P0641409	OIL LINE ELBOW CONNECTOR 4MM

REF	PART #	DESCRIPTION
410	P0641410	OIL LINE TEE CONNECTOR 4MM
411	P0641411	TERMINAL BOARD 6P
412	P0641412	ON/OFF MAGNETIC SWITCH
412-1	P0641412-1	SWITCH BASE
412-2	P0641412-2	CONTACTOR SDE MA-30 220V
412-3	P0641412-3	OL RELAY SDE RA-30 22-34
412-4	P0641412-4	SWITCH COVER
412-5	P0641412-5	SWITCH COVER SCREW
413	P0641413	STRAIN RELIEF 22MM
414	P0641414	STRAIN RELIEF 17MM
415	P0641415	SAFETY SWITCH
416	P0641416	STRAIN RELIEF 14MM
417	P0641417	STRAIN RELIEF 20MM
418	P0641418	POWER CORD
419	P0641419	MOTOR CORD
420	P0641420	OIL LINE 4MM OD



Pneumatic System Breakdown

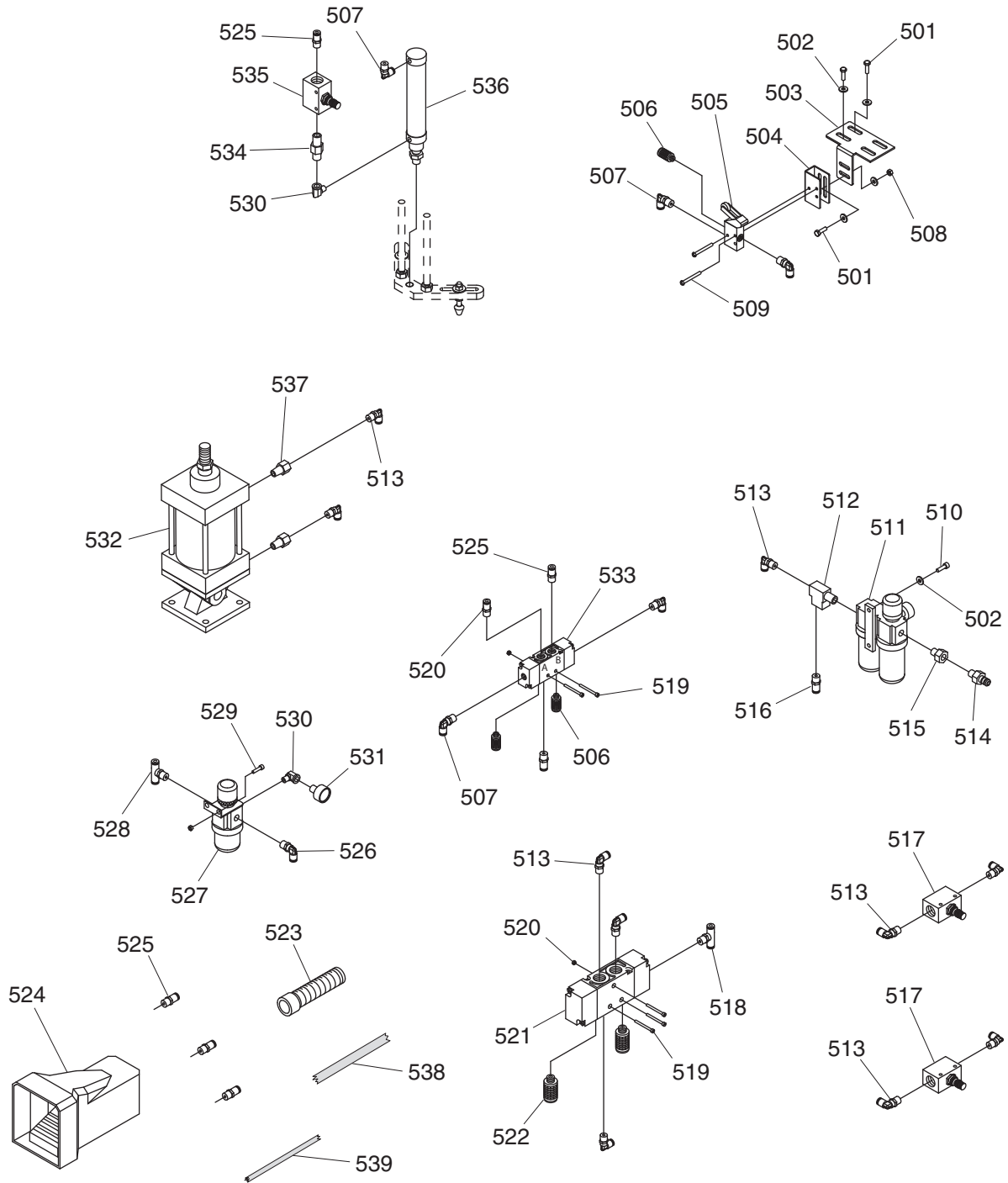

Pneumatic System Parts List

REF	PART #	DESCRIPTION
501	PB83M	HEX BOLT M6-1 X 16
502	PW03M	FLAT WASHER 6MM
503	P0641503	LIMIT SWITCH BRACKET
504	P0641504	LIMIT SWITCH MOUNT
505	P0641505	AIR LIMIT SWITCH
506	P0641506	AIR MUFFLER 1/8"
507	P0641507	MALE ELBOW CONNECTOR 1/8" X 6MM
508	PN01M	HEX NUT M6-1
509	PS18M	PHLP HD SCR M4-.7 X 25
510	PSB01M	CAP SCREW M6-1 X 16
511	P0641511	AIR REGULATOR/LUBRICATOR 3/8"
512	P0641512	TEE CONNECTOR 3/8"
513	P0641513	MALE ELBOW CONNECTOR 3/8" X 8MM
514	P0641514	AIR INLET VALVE 1/4" NPT
515	P0641515	ADAPTER 3/8" X 1/4"
516	P0641516	MALE CONNECTOR 3/8" X 6MM
517	P0641517	ADJUSTABLE PRESSURE VALVE 3/8"
518	P0641518	TEE CONNECTOR 1/8" X 6MM
519	PSB46M	CAP SCREW M4-.7 X 40
520	PN04M	HEX NUT M4-.7

REF	PART #	DESCRIPTION
521	P0641521	VALVE 5-OUTLET
522	P0641522	AIR MUFFLER 3/8"
523	P0641523	FLEXIBLE HOSE 3/4"
524	P0641524	PEDAL SWITCH 1/4"
525	P0641525	MALE CONNECTOR 1/4" X 6MM
526	P0641526	MALE ELBOW 1/4" X 6MM
527	P0641527	AIR PRESSURE REGULATOR 1/4"
528	P0641528	TEE CONNECTOR 1/4" X 6MM
529	PSB33M	CAP SCREW M5-.8 X 12
530	P0641530	ELBOW CONNECTOR 1/8"
531	P0641531	AIR PRESSURE GAUGE 1/4"
532	P0641532	MAIN AIR CYLINDER
533	P0641533	VALVE 6-OUTLET
534	P0641534	CONNECTOR 1/4" X 1/8"
535	P0641535	ADJUSTABLE PRESSURE VALVE 1/4"
536	P0641536	HOLD-DOWN AIR CYLINDER
537	P0641537	ADAPTER 1/2" X 3/8"
538	P0641538	AIR LINE 5MM/ID 8MM/OD
539	P0641539	AIR LINE 4MM/ID 6MM/OD



Label Placement & List

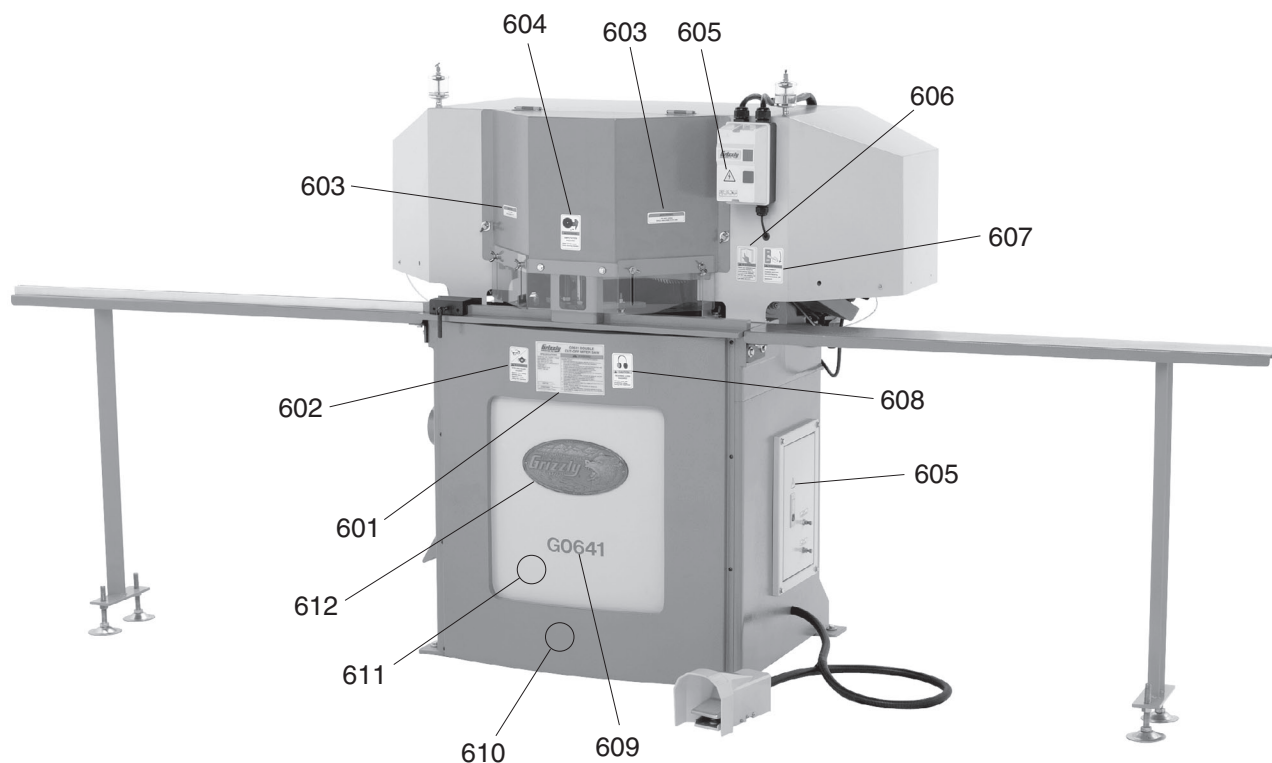

REF	PART #	DESCRIPTION
601	P0641601	MACHINE ID LABEL
602	P0641602	EYE/LUNG HAZARD LABEL VERT
603	P0641603	DO NOT OPEN WARNING LABEL
604	P0641604	AMPUTATION HAZARD LABEL VERT
605	PLABEL-11	ELECTRICITY LABEL
606	PLABEL-12	READ MANUAL LABEL VERT

REF	PART #	DESCRIPTION
607	P0641607	DISCONNECT POWER LABEL VERT
608	PLABEL-15	HEARING HAZARD LABEL VERT
609	P0641609	MODEL NUMBER LABEL
610	PPAINT-1	GRIZZLY GREEN TOUCH UP PAINT
611	PPAINT-11	GRIZZLY PUTTY TOUCH UP PAINT
612	G8588	GRIZZLY NAMEPLATE 9-1/2" X 4-1/2"

!WARNING

Safety labels warn about machine hazards and ways to prevent injury. The owner of this machine **MUST** maintain the original location and readability of the labels on the machine. If any label is removed or becomes unreadable, **REPLACE** that label before using the machine again. Contact Grizzly at (800) 523-4777 or www.grizzly.com to order new labels.







WARRANTY CARD

Name _____

Street _____

City _____ State _____ Zip _____

Phone # _____ Email _____ Invoice # _____

Model # _____ Order # _____ Serial # _____

The following information is given on a voluntary basis. It will be used for marketing purposes to help us develop better products and services. **Of course, all information is strictly confidential.**

1. How did you learn about us?

- | | | |
|--|----------------------------------|----------------------------------|
| <input type="checkbox"/> Advertisement | <input type="checkbox"/> Friend | <input type="checkbox"/> Catalog |
| <input type="checkbox"/> Card Deck | <input type="checkbox"/> Website | <input type="checkbox"/> Other: |

2. Which of the following magazines do you subscribe to?

- | | | |
|---|--|---|
| <input type="checkbox"/> Cabinet Maker | <input type="checkbox"/> Popular Mechanics | <input type="checkbox"/> Today's Homeowner |
| <input type="checkbox"/> Family Handyman | <input type="checkbox"/> Popular Science | <input type="checkbox"/> Wood |
| <input type="checkbox"/> Hand Loader | <input type="checkbox"/> Popular Woodworking | <input type="checkbox"/> Wooden Boat |
| <input type="checkbox"/> Handy | <input type="checkbox"/> Practical Homeowner | <input type="checkbox"/> Woodshop News |
| <input type="checkbox"/> Home Shop Machinist | <input type="checkbox"/> Precision Shooter | <input type="checkbox"/> Woodsmith |
| <input type="checkbox"/> Journal of Light Cont. | <input type="checkbox"/> Projects in Metal | <input type="checkbox"/> Woodwork |
| <input type="checkbox"/> Live Steam | <input type="checkbox"/> RC Modeler | <input type="checkbox"/> Woodworker West |
| <input type="checkbox"/> Model Airplane News | <input type="checkbox"/> Rifle | <input type="checkbox"/> Woodworker's Journal |
| <input type="checkbox"/> Modeltec | <input type="checkbox"/> Shop Notes | <input type="checkbox"/> Other: |
| <input type="checkbox"/> Old House Journal | <input type="checkbox"/> Shotgun News | |

3. What is your annual household income?

- | | | |
|--|--|--|
| <input type="checkbox"/> \$20,000-\$29,000 | <input type="checkbox"/> \$30,000-\$39,000 | <input type="checkbox"/> \$40,000-\$49,000 |
| <input type="checkbox"/> \$50,000-\$59,000 | <input type="checkbox"/> \$60,000-\$69,000 | <input type="checkbox"/> \$70,000+ |

4. What is your age group?

- | | | |
|--------------------------------|--------------------------------|--------------------------------|
| <input type="checkbox"/> 20-29 | <input type="checkbox"/> 30-39 | <input type="checkbox"/> 40-49 |
| <input type="checkbox"/> 50-59 | <input type="checkbox"/> 60-69 | <input type="checkbox"/> 70+ |

5. How long have you been a woodworker/metalworker?

- | | | | |
|------------------------------------|------------------------------------|-------------------------------------|------------------------------------|
| <input type="checkbox"/> 0-2 Years | <input type="checkbox"/> 2-8 Years | <input type="checkbox"/> 8-20 Years | <input type="checkbox"/> 20+ Years |
|------------------------------------|------------------------------------|-------------------------------------|------------------------------------|

6. How many of your machines or tools are Grizzly?

- | | | | |
|------------------------------|------------------------------|------------------------------|------------------------------|
| <input type="checkbox"/> 0-2 | <input type="checkbox"/> 3-5 | <input type="checkbox"/> 6-9 | <input type="checkbox"/> 10+ |
|------------------------------|------------------------------|------------------------------|------------------------------|

7. Do you think your machine represents a good value? Yes No

8. Would you recommend Grizzly Industrial to a friend? Yes No

9. Would you allow us to use your name as a reference for Grizzly customers in your area?
Note: We never use names more than 3 times. Yes No

10. Comments: _____

CUT ALONG DOTTED LINE

FOLD ALONG DOTTED LINE



Place
Stamp
Here



GRIZZLY INDUSTRIAL, INC.
P.O. BOX 2069
BELLINGHAM, WA 98227-2069



FOLD ALONG DOTTED LINE

Send a Grizzly Catalog to a friend:

Name _____
Street _____
City _____ State _____ Zip _____

TAPE ALONG EDGES--PLEASE DO NOT STAPLE

WARRANTY AND RETURNS

Grizzly Industrial, Inc. warrants every product it sells for a period of **1 year** to the original purchaser from the date of purchase. This warranty does not apply to defects due directly or indirectly to misuse, abuse, negligence, accidents, repairs or alterations or lack of maintenance. This is Grizzly's sole written warranty and any and all warranties that may be implied by law, including any merchantability or fitness, for any particular purpose, are hereby limited to the duration of this written warranty. We do not warrant or represent that the merchandise complies with the provisions of any law or acts unless the manufacturer so warrants. In no event shall Grizzly's liability under this warranty exceed the purchase price paid for the product and any legal actions brought against Grizzly shall be tried in the State of Washington, County of Whatcom.

We shall in no event be liable for death, injuries to persons or property or for incidental, contingent, special, or consequential damages arising from the use of our products.

To take advantage of this warranty, contact us by mail or phone and give us all the details. We will then issue you a "Return Number," which must be clearly posted on the outside as well as the inside of the carton. We will not accept any item back without this number. Proof of purchase must accompany the merchandise.

The manufacturers reserve the right to change specifications at any time because they constantly strive to achieve better quality equipment. We make every effort to ensure that our products meet high quality and durability standards and we hope you never need to use this warranty.

Please feel free to write or call us if you have any questions about the machine or the manual.

Thank you again for your business and continued support. We hope to serve you again soon.

grizzly.com

TOOL WEBSITE

Buy Direct and Save with Grizzly® – Trusted, Proven and a Great Value!

*Visit Our Website Today And Discover
Why Grizzly® Is The Industry Leader!*

- SECURE ORDERING
- ORDERS SHIPPED WITHIN 24 HOURS
- E-MAIL RESPONSE WITHIN ONE HOUR

-OR-

Call Today For A **FREE**
Full Color Catalog

1-800-523-4777

